

TECHNICAL MANUAL

**OPERATOR'S AND UNIT
MAINTENANCE MANUAL**

FOR

TEST SET, RADAR

TS-4530/UPM

(NSN 6625-01-483-7194) (EIC:N/A)

DISTRIBUTION STATEMENT A – Approved for public release; distribution is unlimited.

WARNING SUMMARY

This warning summary contains general safety warnings and hazardous materials warnings that must be understood and applied during operation and maintenance of this equipment. Failure to observe these precautions could result in serious injury or death to personnel. Also included are explanations of safety and hazardous materials icons used within the technical manual.

EXPLANATION OF SAFETY WARNING ICONS



ELECTRICAL – electrical wire to hand with electricity symbol running through hand shows that shock hazard is present.



HEAVY OBJECT – human figure stooping over heavy object shows physical injury potential from improper lifting technique.

GENERAL SAFETY WARNINGS DESCRIPTION

WARNING



Whenever possible shut off system power before beginning work on equipment.

Do not come in contact with electrical connectors.

Don't be misled by low voltage. Low potentials can be dangerous.

Do not work on electrical equipment alone. Be sure another person is nearby who can give first aid.

WARNING



Some objects covered in this manual are heavy and need two soldiers to lift them.

EXPLANATION OF HARZARDOUS MATERIALS ICONS

WARNING



CHEMICAL – drops of liquid on hand shows that the material will cause burns or irritation to human skin or tissue.



VAPOR - human figure in a cloud shows that material vapors present a danger to life or health.

EXPLANATION OF HAZARDOUS MATERIALS ICONS – Continued



FIRE – flame shows that a material may ignite and cause burns.



EYE PROTECTION – person with goggles shows that the material will injure the eyes.

HAZARDOUS MATERIALS DESCRIPTION

WARNING



ISOPROPYL ALCOHOL

Isopropyl alcohol vapors are toxic. Avoid prolonged or repeated breathing of vapors or solvent contact with skin. Use only with adequate ventilation. Solvent is flammable and should not be used near open flame. Fire extinguishers should be readily available when solvent is used.



5

SAFETY STEPS TO FOLLOW IF SOMEONE IS THE VICTIM OF ELECTRICAL SHOCK:

1

DO NOT TRY TO PULL OR GRAB THE INDIVIDUAL.

2

IF POSSIBLE, TURN OFF THE ELECTRICAL POWER.

3

IF YOU CANNOT TURN OFF THE ELECTRICAL POWER, PULL, PUSH, OR LIFT THE PERSON TO SAFETY USING A DRY WOODEN POLE OR A DRY ROPE OR SOME OTHER INSULATING MATERIAL.

4

SEND FOR HELP AS SOON AS POSSIBLE.

5

AFTER THE INJURED PERSON IS FREE OF CONTACT WITH THE SOURCE OF ELECTRICAL SHOCK, MOVE THE PERSON A SHORT DISTANCE AWAY AND IMMEDIATELY START ARTIFICIAL RESUSCITATION.

WARNING

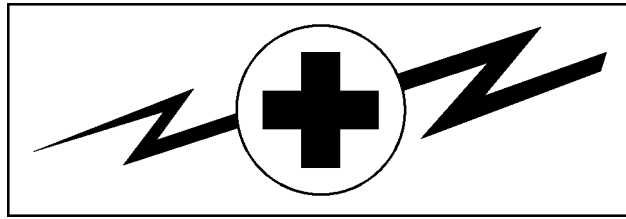

HIGH VOLTAGE

Is used in the operation of this equipment.

DEATH ON CONTACT

May result if personnel fail to observe safety precautions.

Never work on electronic equipment unless there is another person nearby who is familiar with the operation and hazards of the equipment and who is competent in administering first aid. When the technician is aided by operators, they must be warned about dangerous areas.

A periodic review of safety requirements in TB 385-4, Safety Precautions for Maintenance of Electrical/Electrostatic Equipment, is recommended. When the equipment is operated with covers removed, DO NOT TOUCH exposed connections or components. MAKE CERTAIN you are not grounded when making connections or adjusting components inside the test instrument.

Be careful not to contact high-voltage connections or 120/240 Vrms input connections when installing or operating this equipment.

Whenever the nature of the operation permits, keep one hand away from the equipment to reduce the hazard of current flowing through the body.

WARNING

Do not be misled by the term "low voltage". Potentials as low as 50 volts may cause death under adverse conditions.

For First Aid, refer to FM 4-25.11.

WARNING

To avoid explosion, do not operate the equipment in an atmosphere of explosive gas.

WARNING

Use extreme caution not to short positive and negative terminals together when handling NI-CAD batteries. If you short the battery terminals, the battery cells may EXPLODE and cause you INJURY or DEATH.

WARNING

Overheated NI-CAD battery cells can EXPLODE and cause you INJURY or DEATH.

WARNING

Any attempt to charge batteries other than those battery sticks supplied or commercial C-size NI-CAD rechargeable batteries could result in battery EXPLOSION and cause you INJURY or DEATH.

WARNING

Test Set may contain rechargeable batteries.

WARNING

Due to the power potential available at the interrogator interface, always follow operator precautions prescribed by the interrogator system manufacturer.

CAUTION

To prevent damage, never apply solvents to the equipment housing. For cleaning, wipe the equipment with a cloth that is lightly dampened with water, mild detergent, or alcohol. Do not use aromatic hydrocarbons, chlorinated solvents, or methanol-based fluids.

CAUTION

When you put the Test Set down, set it down upright. Do not place the Test Set upside down on antenna. Do not rough handle, drop, or place heavy objects on the Test Set. Otherwise, you may damage the antenna.



Use only cables supplied with Test Set.

CHANGE }
 No. 2 }

**HEADQUARTERS
 DEPARTMENT OF THE ARMY**
 Washington, D.C., 15 June 2006

**OPERATOR'S AND UNIT MAINTENANCE MANUAL
 FOR
 TEST SET, RADAR
 TS-4530/UPM
 (NSN 6625-01-483-7194) (EIC:N/A)**

HAZARDOUS MATERIAL INFORMATION

This document has been reviewed for the presence of solvents containing hazardous materials as defined by the EPCRA 302 and 313 lists by the AMCOM G-4 (Logistics) Environmental Division. As of the base document, dated 15 January 2004, all references to solvents containing hazardous materials have been removed from this document by substitution with non-hazardous or less hazardous materials where possible.

OZONE DEPLETING CHEMICAL INFORMATION

This document has been reviewed for the presence of Class I ozone depleting chemicals by the AMCOM G-4 (Logistics) Environmental Division. As of the base document, dated 15 January 2004, all references to Class I ozone depleting chemicals have been removed from this document by substitution with chemicals that do not cause atmospheric ozone depletion.

DISTRIBUTION STATEMENT A – Approved for public release; distribution is unlimited.

TM 43-6625-916-12, dated 15 January 2004, is changed as follows:

1. File this change sheet in front of the publication for reference purposes.
2. This change is a result of a new distribution statement and is in accordance with contract modification from P00020 to contract DAAH01-02-D-0040.
3. New or updated text is indicated by a vertical bar in the outer margin of the page.
4. Added illustrations are indicated by a vertical bar adjacent to the figure number. Changed illustrations are indicated by a miniature pointing hand adjacent to the updated area and a vertical bar adjacent to the figure number.
5. Remove old pages and insert new pages as indicated below.

Remove Pages

c and d
 A/(B blank)
 i through iv
 Cover

Insert Pages

c and d
 A/(B blank)
 i through iv
 Cover

6. Replace the following work packages with their revised version.

Work Package Number

WP 0001 00
 WP 0027 00
 WP 0030 00

By Order of the Secretary of the Army:

Official:



JOYCE E. MORROW
*Administrative Assistant to the
Secretary of the Army*

0609510

PETER J. SCHOOMAKER
*General, United States Army
Chief of Staff*

Distribution:

To be distributed in accordance with Special Distribution requirements for TM 43-6625-916-12.

CHANGE)
)
 No. 1)

Headquarters
Department of the Army
 Washington, D.C., 25 August 2005

TECHNICAL MANUAL

**OPERATOR'S AND UNIT
 MAINTENANCE MANUAL FOR**

**TEST SET, RADAR, TS-4530/UPM
 (NSN 6625-01-483-7194) (EIC: N/A)**

DISTRIBUTION STATEMENT C – Distribution authorized to U. S. Government agencies and their contractors only, to protect critical technical data on systems or hardware. This determination was made 10 December 2002. Other requests shall be referred to: Program Manager, TMDE, ATTN: SFAE-CSS-ME-TEMOD, Redstone Arsenal, AL 35898-5000.

DESTRUCTION NOTICE – Destroy by any method that will prevent disclosure of contents or reconstruction of the document.

TM 43-6625-916-12, dated 15 January 2004, is changed as follows:

1. File this sheet in front of the manual for reference.
2. This change is a result of Maintenance Transformation Phase II Implementation.
3. New or updated text is indicated by a vertical bar in the outer margin of the page. Completely revised or added chapters or sections are indicated by a vertical bar adjacent to the title only.
4. Added illustrations are indicated by a miniature pointing hand adjacent to the updated area and a vertical bar adjacent to the figure number.
5. Remove old pages and insert new pages as indicated below.

Remove Pages

Insert Pages

A/(B blank)

A/(B blank)

6. Replace the following work packages with their revised version.

Work Package Number

WP 0028 00

TM 43-6625-916-12

C1

By Order of the Secretary of the Army:

PETER J. SCHOOMAKER
General, United States Army
Chief of Staff

Official:



Sandra R. Riley
Administrative Assistant to the
Secretary of the Army

0520012

DISTRIBUTION:

To be distributed in accordance with Special Distribution requirements for TM 43-6625-916-12.

INSERT LATEST CHANGED PAGES/WORK PACKAGES, DESTROY SUPERSEDED DATA.

LIST OF EFFECTIVE PAGES/WORK PACKAGES

NOTE: The portion of text affected by the changes is indicated by a vertical line in the outer margins of the page. Changes to illustrations are indicated by a vertical line adjacent to the title.

Date of issue for original manual and changed pages/work packages are:

Original 0 15 January 2004
 Change 1 25 August 2005
 Change 2 15 June 2006

TOTAL NUMBER OF PAGES FOR FRONT AND REAR MATTER IS 14 AND TOTAL NUMBER OF WORK PACKAGES IS 30, CONSISTING OF THE FOLLOWING:

Page/WP No.	* Change No.	Page/WP No.	*Change No.
Cover.....	2	WP 0012 00.. (2 pages)	0
a through c	0	WP 0013 00.. (2 pages)	0
d	2	WP 0014 00.. (2 pages)	0
e and f.....	0	WP 0015 00.. (2 pages)	0
A	2	WP 0016 00.. (2 pages)	0
B blank	2	WP 0017 00.. (2 pages)	0
i through iv.....	2	WP 0018 00.. (2 pages)	0
CHAPTER 1 TITLE PAGE	0	WP 0019 00.. (2 pages)	0
CHAPTER 1 INDEX	0	WP 0020 00.. (2 pages)	0
WP 0001 00.. (4 pages).....	2	WP 0021 00.. (2 pages)	0
WP 0002 00.. (18 pages)	0	WP 0022 00.. (2 pages)	0
WP 0003 00.. (6 pages).....	0	CHAPTER 4 TITLE PAGE	0
CHAPTER 2 TITLE PAGE	0	CHAPTER 4 INDEX	0
CHAPTER 2 INDEX	0	WP 0023 00.. (2 pages)	0
WP 0004 00.. (4 pages).....	0	WP 0024 00.. (2 pages)	0
WP 0005 00.. (8 pages).....	0	WP 0025 00.. (2 pages)	0
WP 0006 00.. (20 pages)	0	WP 0026 00.. (2 pages)	0
WP 0007 00.. (6 pages).....	0	CHAPTER 5 TITLE PAGE	0
WP 0008 00.. (4 pages).....	0	CHAPTER 5 INDEX	0
WP 0009 00.. (2 pages).....	0	WP 0027 00.. (2 pages)	2
CHAPTER 3 TITLE PAGE	0	WP 0028 00.. (6 pages)	0
CHAPTER 3 INDEX	0	WP 0029 00.. (4 pages)	0
WP 0010 00.. (2 pages).....	0	WP 0030 00.. (2 pages)	2
WP 0011 00.. (2 pages).....	0		

* Zero in this column indicates an original page.

TECHNICAL MANUAL
NO. 43-6625-916-12

HEADQUARTERS
DEPARTMENT OF THE ARMY
Washington, D.C., 15 January 2004

**OPERATOR'S AND UNIT MAINTENANCE MANUAL
FOR
TEST SET, RADAR
TS-4530/UPM
(NSN 6625-01-483-7194) (EIC:N/A)**

REPORTING ERRORS AND RECOMMENDING IMPROVEMENTS

You can help improve this manual. If you find any mistakes or if you know of a way to improve the procedures, please let us know. Mail your letter or DA Form 2028 (Recommended Changes to Publications and Blank Forms) directly to: Commander, U. S. Army Aviation and Missile Command, AMSAM-MMC-MA-NP, Redstone Arsenal, AL 35898-5000. A reply will be furnished to you. You may also provide DA Form 2028 information to AMCOM via email, fax or the World Wide Web. Our fax number is: DSN 788-6546 or Commercial 256-842-6546. Our email address is: 2028@redstone.army.mil. Instructions for sending an electronic 2028 may be found at the back of this manual immediately preceding the hardcopy 2028. For the World Wide Web use: <https://amcom2028.redstone.army.mil>.

HAZARDOUS MATERIAL INFORMATION

This document has been reviewed for the presence of solvents containing hazardous materials as defined by the EPCRA 302 and 313 lists by the AMCOM G-4 (Logistics) Environmental Division. As of the base document, dated 15 January 2004, all references to solvents containing hazardous materials have been removed from this document by substitution with non-hazardous or less hazardous materials where possible.

OZONE DEPLETING CHEMICAL INFORMATION

This document has been reviewed for the presence of Class I ozone depleting chemicals by the AMCOM G-4 (Logistics) Environmental Division. As of the base document, dated 15 January 2004, all references to Class I ozone depleting chemicals have been removed from this document by substitution with chemicals that do not cause atmospheric ozone depletion.

DISTRIBUTION STATEMENT A – Approved for public release; distribution is unlimited.

TABLE OF CONTENTS

	<u>WP Sequence No.</u>
	<u>Page No.</u>
Warning Summary	
Chapter 1 – Introductory Information with Theory of Operation	
Radar Test Set General Information.....	WP 0001
Radar Test Set Equipment Description and Data	WP 0002
Table 2-1. Radar Test Set and Accessories.....	0002 00-2
Figure 2-1. TS-4530/UPM	0003 00-3
Table 2-2. TS-4530 Interrogator Mode Reply Capabilities.....	0002 00-6
Radar Test Set Theory of Operation	WP 0003
Figure 3-1. Test Set Principles of Operation	0003 00-1
Figure 3-2. Antenna Patterns	0003 00-4
Chapter 2 – Operator Instructions	
Radar Test Set Description and Use of Controls and Indicators.....	WP 0004
Figure 4-1. Location of Test Set Controls, Indicators, and Connectors.....	0004 00-1
Table 4-1. Test Set Controls, Indicators, and Connectors	0004 00-2
Figure 4-2. Test Set Display Indicators	0004 00-3
Table 4-2. Test Set Display Indicators.	0004 00-3
Radar Test Set Assembly and Preparation for Use	WP 0005
Figure 5-1. Test Set Battery Stick Installation	0005 00-2
Figure 5-2. KIR-1C Modem 4 Programming Set-up Diagram	0003 00-6
Radar Test Set Operation Under Usual Conditions	WP 0006
Figure 6-1. Menu Structure Chart.....	0006 00-2
Figure 6-2. Direct Connect Mode Operation	0006 00-3
Table 6-1. Transponder Testing Setup Procedure	0006 00-5
Table 6-2. Transponder Manual Tests	0006 00-6
Table 6-3. Transponder Automatic Tests.	0006 00-7
Table 6-4. Transponder Zeroize Mode 4 Code Procedures.....	0006 00-8
Table 6-5. Transponder Mode 4 Code Loading Procedure.....	0006 00-8
Table 6-6. Interrogator/TCAS Testing Setup Procedures	0006 00-11
Table 6-7. Interrogator/TCAS Manual Tests	0006 00-12
Table 6-8. Interrogator/TCAS Sensitivity Test.....	0006 00-14
Table 6-9. Interrogator/TCAS Automatic Tests.	0006 00-14
Table 6-10. Interrogator/TCAS Test Scenario.....	0006 00-15
Table 6-11. Platform Testing Problem Chart.....	0006 00-17

TABLE OF CONTENTS - Continued

	<u>Page No.</u>	<u>WP Sequence No.</u>
Figure 6-3. Test Set Operating Instructions Decal	0006 00-19	
Figure 6-4. Test Set Battery Removal Warning Label.....	0006 00-20	
Radar Test Set Battery Charging and Discharging		WP 0007
Figure 7-1. Location of Battery Charger Controls Indicators, and Connectors	0007 00-2	
Radar Test Set Bench Utility		WP 0008
Figure 8-1. Test Manager Panel.....	0008 00-2	
Figure 8-2. Miscellaneous Panel	0008 00-3	
Radar Test Set Operation Under Unusual Conditions		WP 0009
Table 9-1. Battery Capability Chart	0009 00-1	
Figure 9-1. Test Set Commercial C-size Battery Installation.....	0009 00-2	
 Chapter 3 – Troubleshooting Procedures		
Radar Test Set Malfunction/Symptom Index.....		WP 0010
Table 10-1. Malfunction/Symptom Index.....	0010 00-1	
Power Problems Troubleshooting Section TS001.....		WP 0011
Power Problems Troubleshooting Section TS002.....		WP 0012
Interface Problems Troubleshooting Section TS003.....		WP 0013
Self Check Problems Troubleshooting Section TS004		WP 0014
Self Check Problems Troubleshooting Section TS005		WP 0015
Operational Problems Troubleshooting Section TS006		WP 0016
Self Check Problems Troubleshooting Section TS007		WP 0017
Operational Problems Troubleshooting Section TS008		WP 0018
Operational Problems Troubleshooting Section TS009		WP 0019
Operational Problem Troubleshooting Section TS010		WP 0020
Operational Problems Troubleshooting Section TS011		WP 0021
Utility Software Problems Troubleshooting Section TS012.....		WP 0022
 Chapter 4 – Maintenance Instructions		
Radar Test Set Service Upon Receipt		WP 0023
Radar Test Set Preventive Maintenance Checks and Services (PMCS).....		WP 0024
Table 24-1. Preventive Maintenance Checks and Services.....	0024 00-1	
Radar Test Set General Maintenance Instructions		WP 0025
Radar Test Set Preparation for Storage, Movement, and Shipment		WP 0026
 Chapter 5 – Supporting Information		
Radar Test Set References		WP 0027

TABLE OF CONTENTS – Continued

	<u>WP Sequence No.</u>
	<u>Page No.</u>
Test Set, Radar, TS-4530/UPM Maintenance Allocation Chart (MAC).....	WP 0028
Table 1. MAC for Test Set, Radar, TS-4530/UPM	0028 00-4
Table 2. Tools and Test Equipment for Test Set, Radar, TS-4530/UPM	0028 00-5
Table 3. Remarks for Test Set, Radar, TS-4530/UPM.....	0028 00-6
Radar Test Set Components of End Item (COEI) and Basic Issue Items (BII) Lists	WP 0029
=====	
Radar Test Set Expendable and Durable Items List.....	WP 0030
Table 1. Expendable and Durable Items List	0030 00-1

TM 43-6625-916-12

CHAPTER 1

**INTRODUCTORY INFORMATION
WITH THEORY OF OPERATION**

CHAPTER 1 INDEX

WP Sequence No.

GENERAL INFORMATION.....	0001 00
Scope.....	0001 00-1
Maintenance Forms, Records, and Reports.....	0001 00-1
Reporting Equipment Improvement Recommendations (EIR).....	0001 00-1
Corrosion Prevention Control (CPC).....	0001 00-1
Ozone Depleting Substances (ODS).....	0001 00-1
Destruction of Army Material to Prevent Enemy Use.....	0001 00-1
Preparation for Storage or Shipment.....	0001 00-1
List of Abbreviations/Acronyms.....	0001 00-2
Alphabetical List of Terms.....	0001 00-3
EQUIPMENT DESCRIPTION AND DATA.....	0002 00
Equipment Characteristics, Capabilities, and Features.....	0002 00-1
General Description.....	0002 00-1
Capabilities and Features.....	0002 00-1
Location and Description of Major Components.....	0002 00-1
Radar Test Set and Accessories (Table 2-1).....	0002 00-2
TS-4530/UPM Radar Test Set (Figure 2-1).....	0002 00-3
Specifications and Characteristics.....	0002 00-4
Environmental.....	0002 00-4
User Interface.....	0002 00-5
Modes of Operation.....	0002 00-5
Antenna.....	0002 00-7
Direct Connection Port.....	0002 00-7
Power Supply.....	0002 00-7
Signal Generator.....	0002 00-8
Measurement Receiver.....	0002 00-8
COMSEC Interface.....	0002 00-9
Test Parameters.....	0002 00-9
External Power Supply.....	0002 00-10
External Battery Charger.....	0002 00-10
External DC Cable.....	0002 00-10
Direct Connect RF Cable.....	0002 00-11
KIT/KIR-1C Cable (PN: 55-1045-10).....	0002 00-11
RS-232 Cable.....	0002 00-11
Battery Stick.....	0002 00-11
Transit Case.....	0002 00-11
Bench Utility Software.....	0002 00-11
Accept/Reject Criteria.....	0002 00-12
Transponder.....	0002 00-12
Interrogator.....	0002 00-14
Equipment Markings.....	0002 00-16

CHAPTER 1 INDEX - Continued

THEORY OF OPERATION0003 00

- Test Set Principles of Operation 0003 00-1
 - Test Set Principles of Operation (Figure 3-1) 0003 00-1
- Detail Theory of Operation 0003 00-2
 - External Power Regulator 0003 00-2
 - Battery Charger..... 0003 00-2
 - COMSEC Power Supply 0003 00-2
 - Over Current and Over Temperature Protection 0003 00-2
- Antenna System 0003 00-3
 - Antenna Patterns (Figure 3-2) 0003 00-4
- MTL Measurement Method 0003 00-4
- Interrogator Target Operation 0003 00-5
- External Battery Charger/Discharger (PN: 01-1045-10) 0003 00-5
 - Battery Charging 0003 00-6
 - Battery Discharging..... 0003 00-6

SCOPE

This technical manual contains instructions for operation, checks, adjustments, and corrective maintenance of the Radar Test Set, TS-4530/UPM.

Type of Manual: Operator's and Unit Maintenance Manual.

Model Number and Equipment Names: Radar Test Set, TS-4530/UPM.

Purpose of Equipment: The Radar Test Set, TS-4530/UPM is a small hand-held Test Set. It provides complete flight line and shipboard check out of AIMS transponder and interrogator systems.

MAINTENANCE FORMS, RECORDS, AND REPORTS

Department of the Army forms and procedures used for equipment maintenance will be those prescribed by DA PAM 750-8, The Army Maintenance Management System (TAMMS) Users Manual; DA PAM 738-751, Functional Users Manual for the Army Maintenance Management System-Aviation (TAMMS-A); or AR 700-138, Army Logistics Readiness and Sustainability.

REPORTING EQUIPMENT IMPROVEMENT RECOMMENDATIONS (EIR)

If your Test Set needs improvement, let us know. Send us an EIR. You, the user, are the only one who can tell us what you don't like about your equipment. Let us know why you don't like the design or performance. Put it on an SF 368 (Product Quality Deficiency Report). Mail it to us at Commander, U.S. Army Aviation and Missile Command, AMSAM-MMC-MA-NM, Redstone Arsenal, AL. 35898-5000. We will send you a reply.

CORROSION PREVENTION AND CONTROL (CPC)

Corrosion Prevention and Control (CPC) of Army materiel is a continuing concern. It is important that any corrosion problems with this item be reported so that the problem can be corrected and improvements can be made to prevent the problem in future items.

While corrosion is typically associated with rusting of metals, it can also include deterioration of other materials, such as rubber and plastic. Unusual cracking, softening, swelling, or breaking of these materials may be a corrosion problem.

If a corrosion problem is identified, it can be reported using SF 368, Product Quality Deficiency Report. Use of key words such as "corrosion", "rust", "deterioration", or "cracking" will ensure that the information is identified as a CPC problem.

The form should be submitted to the address specified in DA PAM 750-8, The Army Maintenance Management System (TAMMS) Users Manual.

OZONE DEPLETING SUBSTANCES (ODS)

ODS is not contained in or used with the radar Test Set. The use of ODS in Army IETMs is prohibited.

DESTRUCTION OF ARMY MATERIEL TO PREVENT ENEMY USE

For procedures to destroy this equipment to prevent its use by the enemy, refer to TM 750-244-2, Procedures for Destruction of Electronic Materiel to Prevent Enemy Use (Electronics Command).

PREPARATION FOR STORAGE OR SHIPMENT

Preparation instructions for storage and shipment are found in Work Package 0026 00.

LIST OF ABBREVIATIONS/ACRONYMS

Abbreviation/Acronym

AC	Alternating Current
ADC	Analog-to-Digital Converter
ATCRBS	Air Traffic Control Radar Beacon System
AIMS	ATCRBS IFF Mark XII System
BII	Basic Issue Item
BIT	Built-In Test
BNC	Bayonet Type Connector
CHG	Change
COEI	Component of End Item
COM	Communication
COMSEC	Communications Security
CPC	Corrosion Prevention and Control
DAC	Digital Analog Converter
dB	Decibel
DC	Direct Current
DISCH	Discharge
DoD	Department of Defense
DMA	Direct Memory Access
DSP	Digital Signal Processing
EIR	Equipment Improvement Recommendations
EMI	Electromagnetic Interference
FFT	Fast Fourier Transforms
FPGA	Field Programmable Gate Array
IAW	In Accordance With
IC	Integrated Circuit
IETM	Interactive Electronic Technical Manual
IFF	Identification Friend or Foe
Inter	Interrogator
INTR	Interrogator
I/P	Identification of Position
ISLS	Interrogation Side Lobe Suppression
KIR	Cryptographic Computer for a Transponder
KIT	Cryptographic Computer for an Interrogator
KIV	Cryptographic Computer for a Combined Interrogator Transponder
LED	Light Emitting Diode
LO	Local Oscillator
LRU	Line Replaceable Unit
MDL	Minimum Discernable Level
MOSFET	Metal Oxide Semiconductor Field Effect Transistor
MSPS	Mega Samples Per Second
MTL	Minimum Triggering Level
NSN	National Stock Number
NI-CAD	Nickel-Cadmium Battery
NiMH	Nickel Metal Hydride
nmi/h	Nautical Miles Per Hour
ODS	Ozone Depleting Substance
PC	Personal Computer
PCB	Printed Circuit Board

PMCS	Preventive Maintenance Checks and Services
PN	Part Number
RF	Radio Frequency
RPL	Repair Parts List
RSLs	Receiver Side Lobe Suppression
RX	Receive/Receiver
SIF	Selective Identification Feature
SLS	Side Lobe Suppression
SPI	Serial Peripheral Interface
TA/RA	TCAS Traffic Advisory/Resolution Advisory
TCAS	Traffic Alert and Collision Avoidance System
TEST RPT	Test Repeat
TEST SEQ	Test Sequence
TM	Technical Manual
TNC	Threaded Type Connector
TX	Transmit/Transmitter
UPM	Utility Portable Maintenance
UUT	Unit Under Test
VCO	Voltage Controlled Oscillator
VER BIT A1	Verification BIT A1 word
VER BIT A2	Verification BIT A2 word
WP	Work Package
XPDR	Transponder

ALPHABETICAL LIST OF TERMS

Below is an alphabetical list of some of the terms commonly used in this manual.

Code A or B	Code A refers to the current day's Mode 4 code. Code B refers to the next day's Mode 4 code.
Direct Connect tests	Tests performed by direct cable coupling to the transponder set. Direct Connect testing can be useful when troubleshooting a faulty transponder system. Direct connect tests can be performed at any point between the transponder/interrogator RF connection and the system's antenna cable connection.
Emergency reply	A particular reply by an airborne transponder to indicate that an emergency situation exists in the aircraft. This emergency reply can be transmitted in modes 1, 2, and 3/A.
IFF	Identification friend or foe; a recognition system used primarily for military purposes.
I/P	Identification of Position is a special SIF mode reply (modes 1, 2, and 3/A only) which includes an SPI pulse. The SPI replies are initiated by an IDENT switch on the transponder system control panel.

Mode S	Mode Select – A cooperative surveillance and communication system for air traffic control. Mode S interrogators provide surveillance of both ATCRBS equipped and Mode S equipped aircraft. Mode S transponders will reply to ATCRBS interrogators. Mode S interrogations can be directed to specific Mode S equipped aircraft using a unique 24-bit address assigned to each aircraft.
Multipath angle reflections	A condition that exists when a nearby object(s) causes a portion of the Test Set radiated signal to be reflected. This condition may cause erroneous reply indications. To cure this condition, the Test Set operator should change position (angle or distance) from the target and repeat the test.
Radiated tests	A term used to describe RF over-the-air testing and does not refer to harmful radiations. Radiated tests are performed by free-space coupling between the Test Set and transponder/interrogator antennas. The Test Set operator aims the unit at the transponder/interrogator antenna when performing the test.
SIF modes	A term that refers to modes 1, 2, 3/A, and C. Technically, mode C is not a SIF mode, but is similar to the modes 1, 2, and 3/A.
T C A S	An air-to-air interrogation system that provides traffic advisories to the flight crew (Traffic Alert Collision Avoidance System).
VER BIT 1	Mode 4 Verification bits A1 or B1 produce alternate code sets.

END OF WORK PACKAGE

EQUIPMENT CHARACTERISTICS, CAPABILITIES, AND FEATURES**GENERAL DESCRIPTION**

The Test Set can completely test IFF transponder and interrogator systems as well as Traffic Alert and Collision Avoidance System (TCAS) computer systems. The Test Set adapts its transmitted power level and receiver sensitivity to losses between the Test Set and transponder/interrogator antenna. This provides accurate test results from many positions relative to the transponder/interrogator antenna. The unit can be powered by either one battery stick, six commercial C-size NI-CAD, NiMH, or alkaline batteries, or external power supply. The Test Set is operated using push buttons, and test results are displayed through the viewfinder. Condensed operating instructions are located on the top surface (antenna).

CAPABILITIES AND FEATURES

- Portable by one person
- Rugged
- Weather resistant
- Tests Transponders and Interrogators.
- Tests SIF Modes 1, 2, 3/A, and C.
- Tests Mode 4 (when programmed).
- Tests Mode S.
- Tests TCAS.
- Displays comprehensive test results.
- Powered by one rechargeable battery stick, or six commercial C-size NI-CAD or NiMH rechargeable battery cells, six commercial non-rechargeable alkaline battery cells, or external power supply.
- Comprehensive built-in test and self-calibration capability.
- Supports direct or radiated (over-the-air) testing. Automatically senses direct connection.
- Stores test results (PC downloadable).
- Batteries can be charged while inside Test Set or using supplied external battery charger/discharger (provided with unit).
- Multipath, angle-fault detection (radiated test mode).

LOCATION AND DESCRIPTION OF MAJOR COMPONENTS

The TS-4530/UPM consists of the items listed below. An overall view of TS-4530/UPM is provided in Figure 2-1. The Test Set is a small, hand-held, preflight unit able to completely check out flight line, missile systems, and shipboard AIMS-compatible transponder and interrogator systems. The Test Set and accessories (Table 2-1) are kept in the transit case during shipment and storage. The Test Set has condensed operating instructions located on the top surface.

1. Radar Test Set – Hand-held Test Set that provides complete flight line check out of all AIMS transponder and interrogator systems.
2. Transit Case – The transit case protects the Test Set and accessories during storage and shipment. The transit case has three handles, a hinged lid, and a pressure relief valve.
3. Battery Charger/Discharger – The battery charger is used to charge, discharge, and refresh battery sticks and commercial C-size NI-CAD and NiMH batteries.

Table 2-1. Radar Test Set and Accessories

Fig. 2-1 Item	Qty	Item Name	PN:
1	1	Test Set, Radar, TS-4530/UPM	01-1045-70
2	1	Transit Case and Lid	15-5299-01
3	1	Battery Charger/Discharger	01-1045-10
4	1	Cable, KIT/KIR-1C Interface	55-1045-10
5	1	Cable Assembly, RF Direct Connect	55-1045-11
6	1	DC Power Cable	55-1045-14
7	1	AC Adapter	15-0360-M0
8	2	Battery, Sealed, NI-CAD rechargeable (Battery Stick)	43-0012-00
9	1	RS-232 Cable, 9 Pin	55-1045-15
10	1	CD-ROM, Operator Training Software	60-0694-B1
11	1	CD-ROM, Bench Utility Software	60-0694-B5
12	1	Manual, Operation and Maintenance	06-1045-72
13	1	RF Adapter	30-0225-01
14	1	Power Cord	24-7060-10

4. KIT/KIR-1C Interface Cable – For transponder testing, the KIT/KIR-1C interface cable is used to connect the KIR-1C interrogator computer to the Test Set during code load programming. The cable provides the necessary interface between the Test Set and KIT-1C when testing interrogators. The Test Set provides 28 Vdc to power the KIT/KIR-1C computers. The KIT/KIR-1C Interface Cable provides a power connector for external DC power to operate Test Set and charge Test Set batteries. The Interface Cable also contains an RS-232 connector to allow an external PC to be connected to the Test Set.

NOTE

The KIT/KIR-1C interface cable is not compatible with KIT/KIR-1A computers. Use the optional KIT/KIR-1A cable (PN: 55-1045-16) (not part of COEI).

5. Direct Connect RF Cable - The direct connect RF cable is used to connect the Test Set to the transponder or interrogator during direct connect mode operation.
6. DC Power Cable - The DC power cable is used in conjunction with the KIT/KIR interface cable to power the TS-4530/UPM with an external DC power source.



Indoor use only. Do not expose charger or AC adapter to rain or moisture.

7. AC Adapter - The AC adapter can be used in conjunction with the KIT/KIR interface cable to operate the TS-4530/UPM on standard AC power. It is also used to supply power to the battery charger/discharger unit.

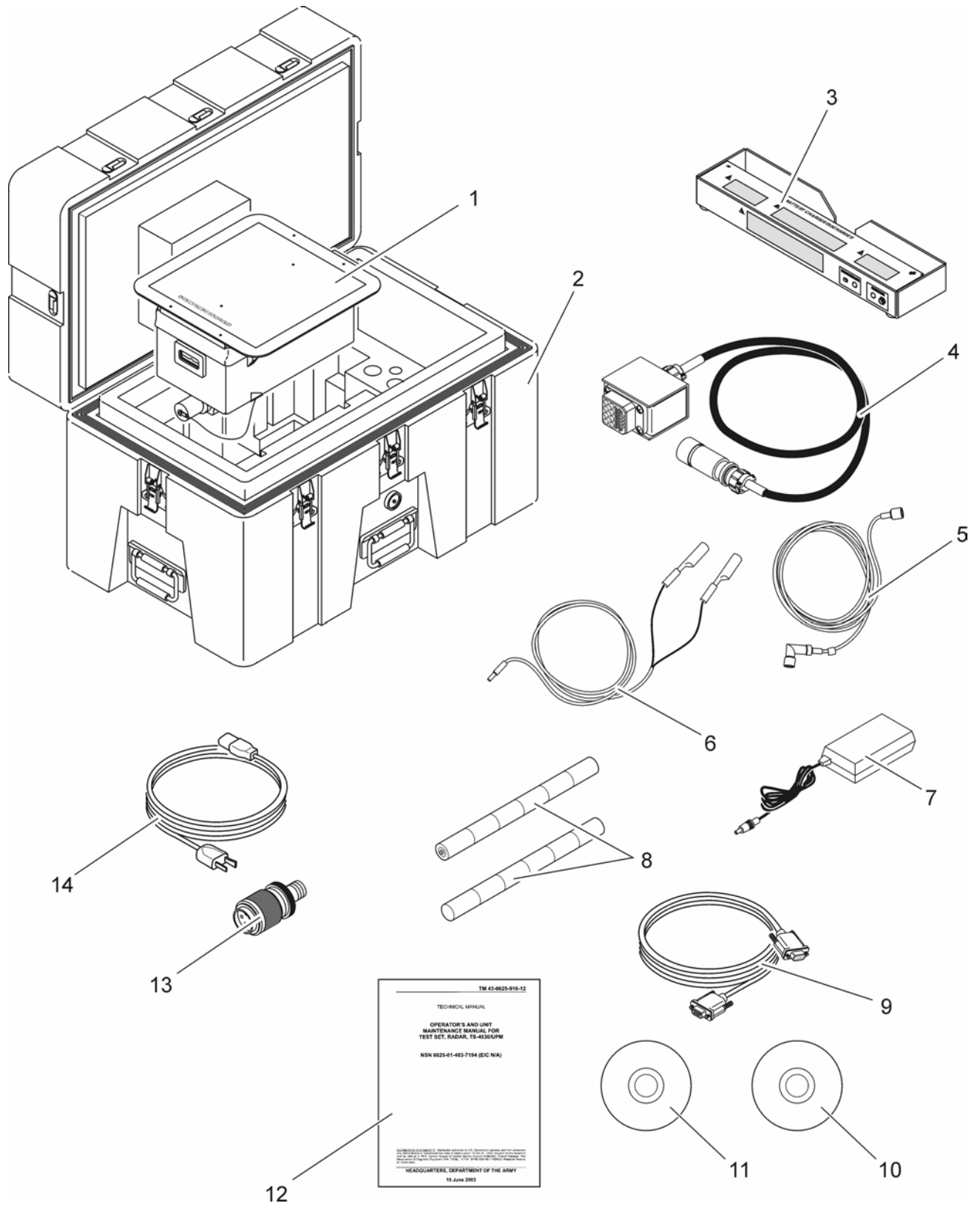

Figure 2-1. TS-4530/UPM

WARNING

Any attempt to charge other than the battery sticks supplied or commercial NI-CAD or NiMH C-size rechargeable batteries could result in battery EXPLOSION and causing INJURY or DEATH. Alkaline batteries must be removed from the Test Set before operation from external power. The Test Set will attempt to recharge any installed batteries when connected to an external source.

8. Battery Stick - The battery stick is the 7.2 V dc power source for the Test Set. It consists of six high capacity, rapid charge, NI-CAD, C-size battery cells. The six battery cells are welded together to form a single battery stick 11.8 inches long. A spare battery stick is supplied.
9. RS-232 Cable - The 9-pin RS-232 cable is used in conjunction with the KIT/KIR interface cable to connect the TS-4530/UPM to a personal computer when running the Bench Utility software. The PC is not provided with the TS-4530/UPM kit.
10. CD-ROM, Operator Training Software - A CD-ROM supplied with the test kit contains the interactive Operator Training Software. This software allows the user to simulate Test Set operation on a PC.
11. CD-ROM, Bench Utility Software - A CD-ROM supplied with the test kit contains the Bench Utility software. This software allows the user to download test data from the TS-4530/UPM and to update direct connect cable loss factors.
12. Manual, TS-4530/UPM Operation and Maintenance - This manual provides operation and field-level maintenance information for the TS-4530/UPM.
13. RF Adapter – Used to convert from a type “N” jack to a type “TNC” plug. May be used with a direct connect cable to adapt the connection to the antenna connector on a transponder or interrogator under test.
14. Power Cord – Used with AC adapter.

SPECIFICATIONS AND CHARACTERISTICS**Environmental**

Physical Dimensions:	(Test Set without accessories)
Length	14.1 inches / 358 mm
Height	7.5 inches / 190 mm
Width	11.5 inches / 292 mm
Weight	<11 lbs. / 4.99 kg (with battery)
Environmental:	MIL-PRF-28800F CLASS 1
Temperature	-40 °C to +55 °C operating, -55 °C to + 85 °C storage.
Humidity	To 100%, Rain Exposure Acceptable
Altitude	Less than 15,000 feet (4572 m) operating, 50,000 feet (15,240 m) storage.
Shock	30 g ½ sine 11 ms
Vibration	Random vibration 6.3 g 10-1000 Hz
Salt Spray	The Test Set, cables, and transit case withstand salt exposure 48 hours in 5% salt atmosphere at 35°C without corrosion.
Fungus	All components are fungus resistant.
EMI / RFI:	MIL-STD-461E
CE101	Power Leads, 30 Hz to 10 kHz

CE102	Power Leads, 10 kHz to 10 MHz
CS101	Power Leads, 30 Hz to 150 kHz
CS114	Bulk Cable Injection, 10 kHz to 200 MHz
CS115	Bulk Cable Injection, Impulse
CS116	Cables & Power Leads, Damped Sinusoidal Transients
RE101	Magnetic, 30 Hz to 100 kHz
RE102	Electric, 10 kHz to 18 GHz (exception ± 5 percent of RX/TX FRE
RE103	Antenna Spurious and Harmonics, 10 kHz to 40 GHz (TX active) EXCEPTION: -50 dBc spurious limit, transmit harmonic levels are not required to be lower than 10dB above the RE102 transmit standby limits
RS101	Magnetic, 30 Hz to 100 kHz
RS103	Electric, 2 MHz to 40 GHz, 200 V/m EXCEPTION: does not apply within 10% of RX and TX operating frequency

User Interface

Display	16 character by 2 line alpha-numeric LED, 0.18" character height with green Accept, red Reject, and yellow Battery indicators
Controls	3 buttons: test sequence advance, test sequence repeat, and test result data

Modes of operation

Transponder Test Modes	<ul style="list-style-type: none"> 1 displays identification status 2 displays code, identification and emergency status 3/A displays code, identification status C displays altitude, identification status 4 stand alone operation, but must be filled with challenge video patterns from COMSEC, supports code A or B, A or B verify S Interrogates with: UF11, UF0, UF4 (requesting DF4), UF5, UF16, UF4 (requesting DF20), UF21 <p>Capable of upgrade to add IFF mode 5.</p>
Interrogator Test Modes	<ul style="list-style-type: none"> 1 responds with Code=12 2 responds with Code=1202 3/A responds with Code=1203 C responds with configurable altitude 4 requires KIT-1C to create correct reply S Replies to: UF11(all call),UF0 (short TCAS surveillance w/conf. alt.), UF16 (long TCAS surveillance w/conf. alt.), UF4(conf. altitude), UF5(Identity = 1204), UF20, UF21 Measures interrogation rate <p>Capable of upgrade to add IFF mode 5.</p>
Interrogator Target Simulation	Refer to Table 2-2.

Table 2-2. TS-4530 Interrogator Mode Reply Capabilities

Interrogation	Target Type				Operational Mode
	Multi	Ident	Emerg	Single	
Mode 1	4,8,16,32,64,128,256 nmi with 6dB level decrease per target	4nmi with ident	4nmi with emergency	4nmi	Manual Mode 1, Auto, Sensitivity
Mode 2	4,8,16,32,64,128,256 nmi with 6dB level decrease per target	4nmi with ident	4nmi with emergency	4nmi	Manual Mode 2, Auto, Sensitivity
Mode 3/A	4,8,16,32,64,128,256 nmi with 6dB level decrease per target	4nmi with ident	4nmi with emergency	4nmi	Manual Mode 3/A, Auto, Sensitivity, ATCRBS Scenario
Mode C	4, 8,16, 32,64,128,256 nmi with 6dB level decrease per target	4nmi with ident	4nmi with emergency	4nmi	Manual Mode C, Auto, Sensitivity, ATCRBS Scenario
Mode 4	4,8,16,32,64,128,256 nmi with 6dB level decrease per target	4nmi	4nmi	4nmi	Manual Mode 4, Auto, Sensitivity
Mode S: UF0	4nmi DF0	4nmi DF0	4nmi DF0	4nmi DF0	Manual Mode S, Auto, Sensitivity, Mode S Scenario
UF4	4nmi DF4	4nmi DF4 with FS=ident	4nmi DF4 with FS=alert	4nmi DF4	Manual Mode S, Auto, Sensitivity, Mode S Scenario
UF5	4nmi DF5	4nmi DF5 with FS=ident	4nmi DF5 with FS=alert	4nmi DF5	Manual Mode S, Auto, Sensitivity, Mode S Scenario
UF11	4nmi DF11	4nmi DF11	4nmi DF11	4nmi DF11	Manual Mode S, Auto, Sensitivity, Mode S Scenario
UF16	4nmi;I DF16	4nmi DF16	4nmi DF16	4nmi DF16	Manual Mode S, Auto, Sensitivity, Mode S Scenario
UF20	4nmi DF20	4nmi DF20 with FS=ident	4nmi DF20 with FS=alert	4nmi DF20	Manual Mode S, Auto, Sensitivity, Mode S Scenario

Table 2-2. TS-4530 Interrogator Mode Reply Capabilities - Continued

Interrogation	Target Type				Operational Mode
	Multi	Ident	Emerg	Single	
UF21	4nmi DF21	4nmi DF21 with FS=ident	4nmi DF21 with FS=alert	4nmi DF21	Manual Mode S, Auto, Sensitivity, Mode S Scenario

Interrogator Scenarios

Intruder Types: Mode A & C only (ATCRBS scenario), Mode S only (Mode S scenario)
 LEVEL: Intruder closing level at configured altitude
 ABOVE: Intruder closing level above configured altitude,
 DIVE: Intruder closing from above descending to configured altitude
 CLIMB: Intruder closing from below climbing to configured altitude.
 Intruder starts at 15 nmi distance from UUT and closes at a rate of 720 kts.

Antenna

Type: Directional antenna with sum and difference feeds
 Interrogation Beamwidth: Approximately ±10 degrees
 Polarization: Vertical
 Test Range: 10 to 150 ft (3 to 46 m) for transponder testing
 30 to 70 ft (9.1 to 21.3 m) for interrogator testing

Direct Connection Port

Impedance: 50 Ω
 SWR: 1.3:1 maximum
 Connector: TNC
 MAX INPUT POWER: +68 dBm at 1% max duty cycle and 1 us max pulse width

Power Supply

NOTE

Alkaline non-rechargeable batteries must be removed before using external power.

Operating Modes: Unit operates either from external DC input power or internal batteries
 External DC Input: 12 to 36 V dc input, 25 W maximum
 Battery Compatibility: Replaceable internal batteries, disassembly of unit is not required. Reverse polarity protected.
 PN: 43-0012-00 NiCad Rechargeable Battery Assy, 7.2 volt DC nominal
 6 x 1.2 V commercial "C" size NiCad Cells
 6 x 1.2 V commercial "C" size NiMH Cells
 6 x 1.5 V Alkaline non-rechargeable "C" cells

Internal Battery Charger	Operates from External DC Input Full recharge time within 8 hours from fully discharged state (actual charge time depends on level of discharge) Battery will charge with unit operating unless an external COMSEC is connected. Automatic charge termination when fully charged Automatic charge restriction to 0 to +40 C nominal battery temperature range Safety charge termination at +85 C nominal battery temperature range
Low Battery Indication	Display indicates "BATTERY" when less than 20 % capacity remains, flashes "BATTERY" at slow rate when less than 5% capacity remains
Discharge Protection	Test Set automatically shuts off to prevent excessive battery discharge.

Signal Generator

Generator Frequency	1030 or 1090 ± 0.01 MHz
Generator Power	+4 to -44 dBm, 1dB resolution, ± 1.5 dB accuracy at antenna connector, +/- 2dB radiated antenna field strength -40 to -88 dBm, 1dB resolution, ± 1.5 dB accuracy at direct port
Pulse shape and timing	Modes 3/A, C, S comply with RTCA/DO-181B, mode 1, 2, 4 comply with DOD AIMS 97-1000
ISLS Amplitude	Equal to P1 on difference or sum ports when enabled.
Interrogation Rate	(transponder test mode)
Modes 1,2,3/A,C,4	235 +/- 5 Hz
Mode S	50 +/- 5 Hz (short), 12.5 +/-5 Hz (long)
Harmonics	2 nd and 3 rd harmonic >30 dBc
Spurious	Applies at greater than 60 MHz from TX center frequency -50 dBm maximum in standby / 50 dBc or -50 dBm max in transmit when measured at the antenna connection.

Measurement Receiver

General	
Frequency Range	1090 or 1030 MHz
Amplitude Range	+68 to +20 dBm at direct port, +24 to -24 dBm at antenna port
Input Protection	(1us pulse width, 1% max duty cycle)
Direct Input	+68 dBm
Antenna Input	+30 dBm at antenna connection

NOTE

The minimum recommended antenna distance to prevent damage is 3 feet (1 meter) from an active transponder antenna, and 16 feet (3 meters) from an active high-power interrogator antenna.

Receiver Measurements

Received Power	0.1dB resolution, ± 1.5 dB accuracy at antenna port, ± 1.5 dB at direct port, +/- 2dB antenna field strength
Method	Peak power of pulse obtained using 100 ns averaging period
Frequency	0.01 MHz resolution +/-0.10 MHz accuracy with >400ns pulse width (transponder mode) +/-0.05 MHz accuracy with >750ns pulse width (interrogator mode)

Method	Average frequency between 90% points
Frequency range	Within ± 5 MHz of nominal for specified accuracy of amplitude and frequency measurements
Pulse Spacing	± 25 ns measured between leading edges for pulses with rise times ≤ 100 ns
Pulse Width	± 25 ns for pulses with rise times of 50 to 100 ns, fall times of 50 to 200 ns
Receiver Bandwidth	> 10 MHz at 3 dB points
Oscillator Leakage:	-50 dBm maximum at antenna connection
Image Rejection:	> 40 dBc

COMSEC Interface

Connector	Accessory interface cable or adapter provides the required interface connector
Compatibility	KIT-1C, KIR-1C, KIT-1A or KIR-1A with appropriate cable or adapter
Video Outputs	Enable Trigger, Challenge Video, Pretrigger, Reply Video
High State	2.5 volts minimum into 90 ohm, 5 volts maximum (high impedance)
Low State	0.3 volts maximum at -1 ma
Output Impedance	60 ohms nominal
Video Inputs	Disparity, Reply Video, Challenge Video, Time Decoded Video
High State	2.0 volts minimum, 5.5 volts maximum
Low State	0.5 volts maximum
Input Impedance	1k ohm nominal
Signaling Outputs	Code A/B, Verify Bit 1, Code Hold
High State	3.0 Volts minimum with 5 mA load to ground may be pulled up to > 5 Volts if current is limited to 20 mA as the output is clamped at > 5 Volts
Low State	0.3 Volt maximum when sinking < 100 mA
Signaling Inputs	TX Alarm, INT Alarm
High State	2.0 volts minimum
Low State	0.5 volts maximum at -1 mA
Input Impedance	.7k ohm to +5 volts nominal
Power for COMSEC	
KIT-1A / KIR-1A	External 115 v ac provided through KIT/KIR-1A interface cable (JPN: 55-1045-16) (not part of COEI)
KIT-1C / KIR-1C	22 to 29 Vdc at 3 watts max. (provided by the TS-4530 unit)
KIV-6	15 +/- 0.75 Vdc at 200 mA max. (provided by the TS-4530 unit) (not part of COEI)
Code Retention	An attached COMSEC will retain code during standby and off conditions. The Mode 4 interrogation patterns stored in the TS-4530 can be manually zeroized. An attached COMSEC computer can be manually zeroized from its front panel. Twelve samples of Mode 4 interrogation pattern + response obtained from the interrogator computer are stored for code A, B, A verify, and B verify.

Test Parameters

Correct reply code	Indicates reply code
Correct pulse timing	Displays pulse spacing error or pulse width error
No or low replies	Indicates % reply
Receiver sensitivity (XPDR)	Displays MTL in dBm if direct connect, effective received MTL in dBm with antenna.
Receiver Sensitivity (INTR):	MDL Test allows selecting target reply level from 0 to -12 dB in 1 dB steps relative to nominal target level.
Transmitter power	Displays power in dBm if direct connect, effective radiated power in dBm with antenna

EQUIPMENT DESCRIPTION AND DATA - Continued

Transmitter Frequency	Displays frequency
Round Reliability	% replies in degraded display
Mode 4 word	Indicates presence of A or B word
VER BIT 1 word	Indicates presence of A1 or B1 word
Mode 4 time delay	Indicates pass / fail only
ISLS Operation	Indicates % reply
Identify Response	Indicates presence
Emergency Response	Indicates presence
Angle Reflection	Indicates unacceptable levels of multipath interference
Direct Connect testing	Connector provided for direct connection to transponder
Mode S testing	Supports the RF link portion of the installed equipment performance requirements of DO-181B and ED-73A (Additional equipment is required to simulate aircraft pressure altitude for the altitude reporting verification.)
Pass / Fail Limits	Default limits are as specified in AIMS / ARINC specifications. Refer to Accept /Reject Criteria in this Work Package.

External Power Supply

Temperature	0 to +40 C
Altitude	Less than 2,000 m operating
Humidity	10 to 80% non-condensing, indoor operation only
Weight	1 lbs. / 0.45 kg
Input Voltage	100 to 240 V ac +/- 10%
Input Current	1.0 A AC Max
Frequency	47 to 420 Hz
Input Connector	IEC 320 3 pin receptacle, 6' (USA standard line cord provided)
Output Connector	6 foot / 1.8 meter cable with 5.5 x 2.5 x 9.5mm barrel connector
Output Voltage	+12V dc nominal
Output Current	3.0 ADC nominal
EMC	FCC class B, CISPR 22 class B
Approvals	UL, CE, UDE, CSA

External Battery Charger

Temperature	0 to +40 C
Altitude	Less than 2,000 m operating
Humidity	10 to 80% non-condensing, indoor operation only
Weight	1 lbs. / 0.45 kg
Size	12.2" L x 2" H x 3.3' W
Functions	Charges or discharges one battery stick
Power Source	Requires connection to supplied AC Adapter, 12Vdc \pm 0.5V, 2 A min, 4 A max.
Input Connector	Accepts 5.5 x 2.5 x 9.5mm barrel connector
Charge time	3 hours maximum for 3AH battery, dependent on battery charge state Automatic shut off when fully charged.
Discharge rate	700 mA typical, automatic shut off or recharge when discharge completed

External DC Cable

Supply Connector	Banana Plugs / Alligator Clips
Unit Connector	5.5 x 2.5 x 9.5mm barrel connector
Length	6 foot / 1.8 meter
Weight	.22 lb / 0.1 kg

Direct Connect RF Cable

Length	12 feet / 3.6 meters
Connectors	TNC male right angle, TNC male straight TNC female to N male adapter included
Weight	0.5 lb. / 0.25 kg

KIT/KIR-1C Cable

Supported COMSEC	KIT-1C / TSEC, KIR-1C / TSEC
Length	4 foot / 1.2 meters
Weight	2 lbs. / 0.9 kg
RS-232 connector	9 pin D sub female
COMSEC connector	ON089560 or equivalent.
External DC connector	Accepts 5.5 x 2.5 x 9.5mm barrel connector
KIT/KIR Power	28 volt nominal at 3 watts max supplied from Test Set

RS-232 Cable

Connectors	9 pin D sub male / female
Length	5 foot
Weight	0.22 lb / 0.1 kg

Battery Stick

Type	High Capacity Rapid Charge NiCad
Voltage	7.2 volts DC nominal
Capacity	3 amp hour at +25 C nominal
Temperature	
Operating	-20 to +55 C recommended Will operate at -40 C with 25% of +25 C capacity and degraded cycle lifetime
Storage	-55 to +85 C
Recharging	0 to +40 C
Weight	1.5 lbs.

Transit Case

Type	Watertight sealed enclosure with pressure release valve
Size	
Length	26.00 inches/ 660 mm
Height	16.00 inches / 406 mm
Width	16.00 inches / 406 mm
Weight	
Empty:	17 lbs./ 7.7 kg
Full:	37 lbs. / 16.8 kg

Bench Utility Software

Function	Allows download, viewing, and saving test data from Test Set.
Compatibility	Microsoft Windows 95, 98, 2000, NT 4.x
Format	CD ROM

ACCEPT/REJECT CRITERIA

The TS-4530/UPM illuminates the green ACCEPT indicator or the red REJECT indicator to indicate the status of the transponder or interrogator unit under test. This section contains the criteria used by the host processor in the TS-4530 to make the accept/reject decision. The host processor makes these decisions based on information from the DSP processor. The DSP processor performs an initial pre-screen of the signals from the transponder or interrogator unit under test. A gross failure of the unit under test will usually result in an indication of No Reply that would cause the red REJECT indicator to illuminate. In this case, additional information about the unit under test (such as reply delay or transmitter frequency) would not be available since no reply is available to measure.

The following is a list of characteristics of the transponder or interrogator system that are measured by the Test Set. These measurements are available to the user:

- Transmitter Power
- Receiver MTL/MDL
- Transponder code
- Mode S aircraft address
- EMERGENCY flag
- I/P flag
- Mode C altitude
- Mode S uplink / downlink type

Refer to Test Set Operating Instructions (WP0006 00) for a more detailed description of accept/reject decisions made by the user. Refer to the Theory of Operation section for hardware related details.

TRANSPONDER**NOTE**

All measurements are performed on replies from the transponder under test to 12 interrogations from the TS-4530/UPM at a level 3 dB above measured MTL. These measurements can be saved in the TS-4530/UPM memory and recalled for printout via the Bench Utility software (WP0008 00).

SIF MODES (Mode 1, Mode 2, Mode3/A, Mode C)

Percent Reply	90 %	MIN	n/a	MAX
ISLS Percent Reply	n/a	MIN	10 %	MAX
Reply Delay ¹				
Direct Connect	2.40 uS	MIN	3.60 uS	MAX
Radiated ²	2.40 uS	MIN	3.60 uS	MAX

¹ Measurement is an average of the valid responses to twelve interrogations.

² Reply Delay measurements are decreased by approximately 2 ns per foot distance from aircraft in radiated tests. (At user distance of 100 ft, limits would be 2.60 us min, 3.80 us max.)

The following measurements are performed on the F1 and F2 pulses transmitted by the transponder under test.

Pulse Frequency ^{1,3}	1086.90 MHz MIN	1093.10 MHz MAX
Pulse Width ¹	0.30 uS MIN	0.60 uS MAX
Pulse Spacing ^{1,4}	nominal -0.15 uS MIN	nominal +0.15 uS MAX

Pulse Spacing limits are calculated relative to the nominal specified spacing of F1 and F2.

In addition to the F1 and F2 pulse measurements, all other pulses in the reply transmitted by the transponder under test are verified internally to be within +/-0.15 uS of nominal. The measurement data for these other pulses is not available to the user.

If the transponder was tested by directly coupling to the antenna cable the following are evaluated.

Pulse Power ^{1,3,5}	52.5 dBm MIN	61.5 dBm MAX
Receiver sensitivity (MTL) ⁶	-72 dBm MIN	-80 dBm MAX

If the transponder was tested by an over-the-air measurement the following are evaluated.

Pulse Power ^{1,3}	51.5 dB MIN	62.5 dB MAX
Receive sensitivity	-71 dB MIN	-81 dB MAX

Mode 4

Percent Reply	80 % MIN	n/a MAX
ISLS Percent Reply	n/a MIN	10 % MAX
Reply Delay ¹		
Direct Connect	200.00 uS MIN	203.35 uS MAX
Radiated ²	200.00 uS MIN	203.35 uS MAX

Since a Mode 4 reply can occur in a specified random position, reply delay measurements for Mode 4 are normalized to the first reply position and compared to the limits above.

The following measurements are performed on the R1 and R3 pulses transmitted by the transponder under test.

Pulse Frequency ^{1,3}	1086.90 MHz MIN	1093.10 MHz MAX
Pulse Width ¹	0.30 uS MIN	0.60 uS MAX
Pulse Space ^{1,4}	nominal -0.15 uS MIN	nominal +0.15 uS MAX

³ The average value of all the Frequency and Power measurements is displayed on the TS-4530/UPM screen by pressing the S3 button to access the parametric data.

⁴ Pulse spacing is not relevant for the first pulse.

⁵ For direct connect pulse power measurement, the cable loss factor is added to the measurement.

⁶ Receiver sensitivity is determined by a greater than 80% reply rate to twelve interrogations.

Pulse Spacing limits are calculated relative to the nominal specified spacing of R1 and R3.

In addition to the R1 and R3 pulse measurements, reply pulse R2 is verified by the Test Set to be within +/-0.15 uS of nominal. The measurement data for R2 is not available to the user.

If the transponder was tested by directly coupling to the antenna cable the following are evaluated.

Pulse Power ^{1,3,5}	52.5 dBm MIN	61.5 dBm MAX
Receiver Sensitivity (MTL) ⁶	-72 dBm MIN	-80 dBm MAX

If the transponder was tested by an over-the-air measurement the following are evaluated.

Pulse Power ^{1,3}	51.5 dBm MIN	61.5 dBm MAX
Receiver Sensitivity (MTL) ⁶	-71 dBm MIN	-81 dBm MAX

Mode S

All measurements are made using the data from the all-call response (DF11).

Percent Reply	80 %	MIN	n/a	MAX
ISLS Percent Reply	n/a	MIN	10 %	MAX
Reply Delay ¹				
Direct Connect	127.65 uS	MIN	128.35 uS	MAX
Radiated ²	127.65 uS	MIN	128.35 uS	MAX

The following measurements are performed on the P1 (pulse 1) and the last data pulse (pulse 64) transmitted by the transponder under test.

Pulse Frequency ^{1,3}	1086.90 MHz	MIN	1093.10 MHz	MAX
Pulse Width ¹	0.40 uS	MIN	0.60 uS	MAX
Pulse Space ^{1,4}	nominal -0.10 uS	MIN	nominal +0.10 uS	MAX

Width and position data of all other pulses in the transponder reply are checked for validity (+/-0.15 uS tolerance from nominal). However, the user has access to measurement data for P1 and the last data pulse only.

If the transponder was tested by directly coupling to the antenna cable the following are evaluated.

Pulse Power ^{1,3,5}	54 dBm MIN	60 dBm MAX
Receiver sensitivity(MTL) ⁶	-78 dBm MIN	-74 dBm MAX

If the transponder was tested by an over-the-air measurement the following are evaluated.

Pulse Power ^{1,3}	51.5 dBm MIN	61.5 dBm MAX
Receiver Sensitivity (MTL) ⁶	-71 dBm MIN	-81 dBm MAX

INTERROGATOR

NOTE

All measurements are performed on an average of the last 12 valid interrogations from the Interrogator under test. The measurements assume the distance between the Test Set and the interrogator antenna on the aircraft is the distance stored in the TS-4530 setup menus. These measurements can be saved in the TS-4530/UPM memory and recalled for printout via the Bench Utility software (refer to WP0008 00).

SIF MODES (Mode 1, Mode 2, Mode3/A, Mode C)

The following measurements are performed on interrogation pulses P1 and P3:

Pulse Frequency ^{1,3}	1029.70 MHz MIN	1030.30 MHz MAX
Pulse Width ¹	0.65 uS MIN	0.95 uS MAX
Pulse Spacing ^{1,4}	nominal -0.10 uS MIN (Mode 1)	nominal +0.15 uS MAX
	nominal -0.15 uS MIN (Mode 2, 3/A, C)	nominal +0.15 uS MAX

If the interrogator was tested by directly coupling to the antenna cable the following is evaluated.

Pulse Power ^{1,3,5}	30 dBm MIN	82 dBm MAX
------------------------------	------------	------------

If the interrogator was tested by a radiated over-the-air measurement, the following is evaluated.

Pulse Power ^{1,3}	30 dBm MIN	82 dBm MAX
----------------------------	------------	------------

If the interrogator was tested by over-the-air, received power is measured by the TS-4530/UPM and corrected for distance path loss (56.4 dB at the 50-foot distance).

Mode 4

The following measurements are performed on P1 and P4 of the received UUT interrogation.

Pulse Frequency ^{1,3}	1029.70 MHz MIN	1030.30 MHz MAX
Pulse Width ¹	0.35 uS MIN	0.65 uS MAX
Pulse Spacing ^{1,4}	nominal -0.15 uS MIN	nominal +0.15 uS MAX

Width and position data of all pulses in the interrogation are checked for validity (+/-0.15 uS tolerance from nominal). However, the user has access to measurement data for P1 and P4 only.

If the interrogator was tested by directly coupling to the antenna cable the following is evaluated.

Pulse Power ^{1,3,5}	30 dBm MIN	82 dBm MAX
------------------------------	------------	------------

If the interrogator was tested by a radiated over-the-air measurement, the following is evaluated.

Pulse Power ^{1,3}	30 dBm MIN	82 dBm MAX
----------------------------	------------	------------

If the interrogator was tested over-the-air, received power is measured by the TS-4530/UPM and corrected for the distance path loss.

Mode S

The following measurements are performed on P1 and P6 of the received UUT interrogator.

Pulse Frequency ^{1,3}	1029.70 MHz MIN	1030.30 MHz MAX
Pulse Width ¹	0.65 uS MIN (P1)	0.95 uS MAX
	29.95 uS MIN (P6 Long)	30.55 uS MAX
	15.95 uS MIN (P6 Short)	16.55 uS MAX
Pulse Spacing ^{1,4}	nominal -0.05 uS MIN	nominal +0.05 uS MAX

Width and position data of P2 is also checked for validity (+/-0.15 uS tolerance from nominal). However, the user has access to measurement data for P1 and P6 only.

If the interrogator was tested by directly coupling to the antenna cable the following is evaluated.

Pulse Power ^{1,3,5}	30 dBm MIN	82 dBm MAX
------------------------------	------------	------------

If the interrogator was tested by a radiated over-the-air measurement, the following is evaluated.

Pulse Power ^{1,3}	30 dBm MIN	82 dBm MAX
----------------------------	------------	------------

If the interrogator was tested over-the-air, received power is measured by the TS-4530/UPM and corrected for distance path loss.

EQUIPMENT MARKINGS

The following markings may appear on the TS-4530/UPM equipment:



Direct current. This symbol indicates that the equipment requires direct current input.

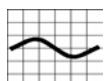

Alternating current. This symbol indicates that the equipment requires alternating current input.

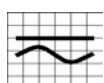

Both direct and alternating current. This symbol indicates that the equipment requires either ac or dc input at the same connector.



Three-phase alternating current. This symbol indicates that the equipment requires 3-phase ac input.

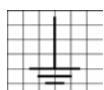

Earth (ground) terminal. This symbol indicates the ground (earth) terminal.

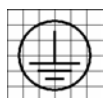

Protective conductor terminal. This symbol indicates the protective ground (earth) terminal.

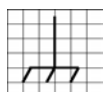

Frame or chassis terminal. This symbol indicates the frame or chassis terminal for connection to ground.

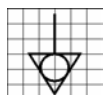

Equipotentiality. This symbol indicates an equipotentiality terminal.

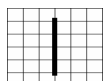

On (Supply). This symbol indicates that the power line switch is ON.

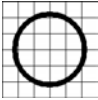

Off (Supply). This symbol indicates that the power line switch is OFF.

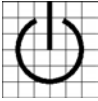

Standby. This symbol indicates that the power line switch is in STANDBY.

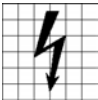

Caution, risk of electric shock. Danger – high voltage.

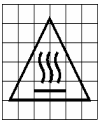

Caution, hot surface. Danger – high temperature surface.



Caution (refer to accompanying documents). Attention – refer to the manual. This symbol indicates that information about usage of a feature is contained in the manual.



CE Mark. TM of the European Community.



Fuse Symbol. To indicate a fuse.

END OF WORK PACKAGE

TEST SET PRINCIPLES OF OPERATION

Figure 3-1 illustrates the general operation of the Test Set. Operator control of all test functions is provided via three buttons (S1, S2, and S3) located on the unit handgrip. Once power is applied to the unit and the Built-In Test (BIT) is complete, transponder or interrogator testing may begin. Testing is performed while aiming the Test Set at the UUT's (Unit Under Test) antenna through the unit viewfinder (radiated test mode) or via RF test cable (direct connect test mode). Prompts are displayed to the user to assist in operation of the Test Set and test results are displayed to verify transponder/interrogator status and to assist in diagnosing system performance abnormalities. An alphanumeric display is located below the viewfinder inside the Test Set enabling the operator to continue aiming the Test Set while reading prompts and test results. Test results for as many as 100 tests may be stored if desired and downloaded to a PC via RS-232 port (the port is accessed by way of the RS-232 connector located on the KIT/KIR interface cable).

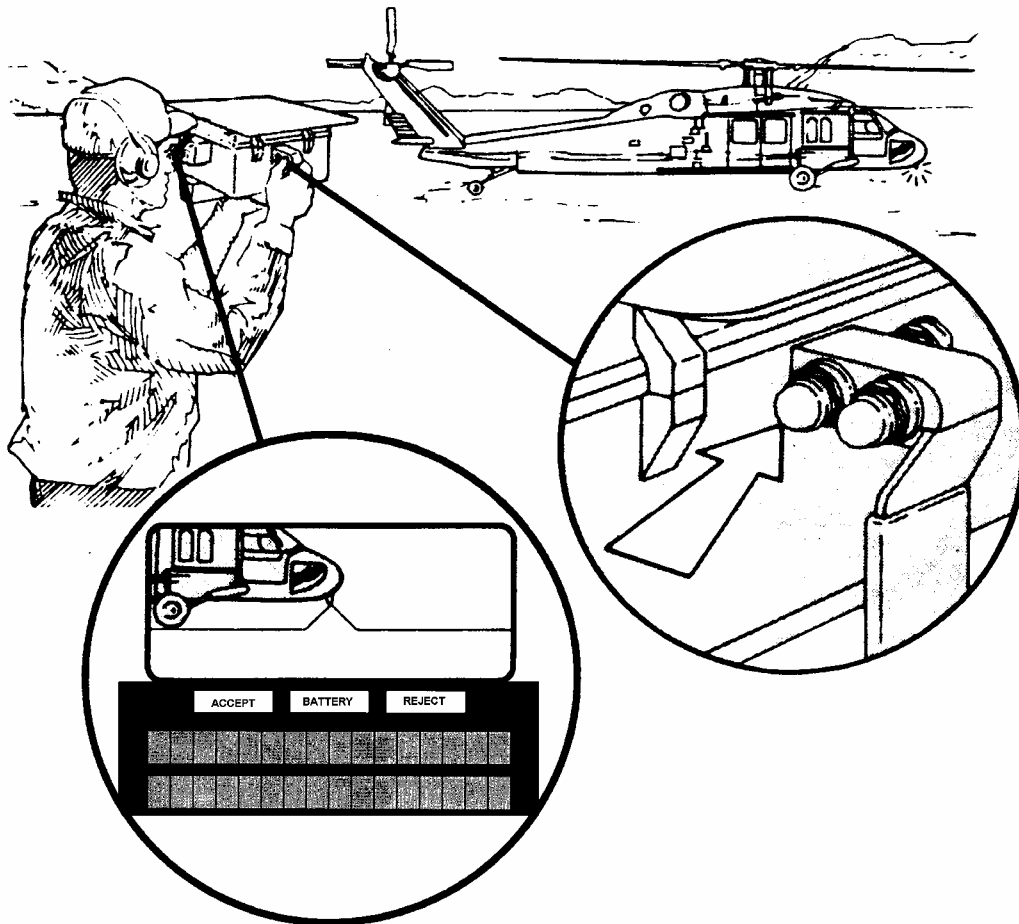

Figure 3-1. Test Set Principles of Operation

When power is initially applied to the Test Set, i.e. a battery stick is installed or external dc power is applied with no batteries installed, the unit performs a BIT test of approximately 5 seconds duration. The results of the self test are displayed once completed. After power is applied, the unit has two operating states. They are active mode and standby mode. The Test Set transitions from active to standby mode after approximately one minute has passed with no operator input (no Test Set buttons pushed). Standby mode is a battery-power conservation state. Power is removed from the display and other non-essential circuits while in this

state. The active-state configuration settings are stored when the unit transitions to standby mode. To restore the Test Set to the active state press any button (S1, S2, or S3). The display and all settings return to their pre standby-mode state and the unit is fully operational.

Starting a test initiates a self-calibration cycle if the Test Set detects either of the following two conditions:

1. Thirty (30) minutes or more has passed since the last self-calibration.
2. A change in temperature of five (5) degrees C or more is detected since the previous self-calibration.

Self-calibration performs the following calibration functions:

1. Received Amplitude
2. Transmit Amplitude
3. Tracking Filters (transmit and receive)

DETAILED THEORY OF OPERATION

External Power Regulator

External 12 to 28 V (nominal) power is EMI filtered and regulated down to +10V by the switching regulator to power the Test Set. Diodes are used to select either the 10 Volts or the battery voltage. Since the 10 volts is always greater than the battery voltage, the Test Set load is automatically removed from the batteries when external power is present.

Battery Charger

Ten (10) volts from the regulator powers a constant current source for charging the battery. The current source is controlled by an integrated circuit that checks for the presence of a battery, limits the charging temperature range, and terminates charging when the battery is fully charged. The IC determines that a battery is fully charged by detecting the small voltage drop that occurs when NiCad or NiMH batteries are fully charged under constant current. For safety purposes, backup charge termination is also provided by a temperature sensor which shuts down the charger to prevent battery overheating.

COMSEC Power Supply

The Test Set supplies power to the external KIR-1C computer for code loading. This eliminates the need for a 28 V dc or 115 V ac source during code loading. The power supply is enabled by the Test Set during code loading, and supplies 28 V dc at up to 5 watts. In addition, the supply provides power to the KIT-1C COMSEC when attached during interrogator testing. The Test Set COMSEC power supply is not compatible with KIT-1A or KIR-1A computers because of their higher power requirements.

Over Current and Over Temperature Protection

The TS-4530/UPM Test Set provides over current protection for power supplied from the internal battery and from external power. This protection is provided by a device for each power source that will automatically switch to a high impedance state when exposed to excessive current. These devices will automatically reset when power is removed. Disconnect the Test Set from external power and remove the battery for a period of 1 minute at room temperature to insure resetting of the protective device. If the Test Set is at an elevated temperature, the protective device will take longer to reset. Allow the unit to cool to room temperature to insure proper resetting of the protective device.

The Test Set also incorporates a safety thermostat in the battery compartment to reduce the possibility of battery venting due to excessive temperatures. If the battery compartment temperature exceeds approximately 80 degrees C, the battery will be disconnected. The thermostat will automatically reset when it cools to approximately 40 degrees C. Disconnect external power and remove the battery, then allow the unit to cool for one hour at room temperature to reset the thermostat. The thermostat responds to any excessive

temperature, and therefore may be activated if the unit is exposed to excessive temperatures during shipping or storage.

The external battery charger also provides for over current protection of the battery with a device that automatically switches to a high impedance state when overloaded. The device will automatically reset when power is disconnected and the battery removed for a period of one minute at room temperature.

ANTENNA SYSTEM

When using a flight line Test Set that communicates via RF, testing errors can result from the RF test signals reflecting off of surrounding metal objects (such as nearby hangers or utility vehicles), or responses from other nearby transponders. The Test Set may detect a signal from a transponder on a nearby aircraft if the UUT transponder is defective. This could inadvertently lead an operator to believe that the UUT is a GO when in actuality the Test Set detected a GO from the transponder on a nearby aircraft. The Test Set utilizes several techniques to solve these problems. The Test Set has a dual pattern antenna to help prevent these potential problems from producing invalid test results. Additionally, the Test Set applies power and receiver sensitivity limits based on the user selected distance to help indicate the inadvertent interrogation of the incorrect aircraft.

Operation of the TS-4530/UPM, antenna system is similar to the operation of the basic Transponder/Interrogator system, which utilize a reply suppression pulse to inhibit the transponder from replying except when it is in the center of the interrogation beam (Refer to Figure 3-2.). This system operates by using two antenna patterns, with the main (sum) antenna pattern radiating the interrogation signal. A second antenna pattern (difference) provides a low response in the main beam and higher response off to the sides, and is used to radiate a suppression pulse (Side Lobe Suppression, or SLS pulse). If the transponder is not located in the center of the main beam, the suppression pulse is received by the transponder at equal or greater amplitude than the interrogation pulses and the transponder does not reply.

The TS-4530/UPM (interrogator) dual antenna system can also be used during reception of the transponder's reply to determine if the signal came from the direction the antenna is pointed (Refer to Figure 3-2.). The TS-4530/UPM receiver uses this method to determine if the reply source was the targeted transponder, a non-targeted transponder, or was a reflection. If the reply signal strength is much stronger on the sum antenna than the difference antenna, the Test Set accepts and processes the reply. If the difference antenna signal approaches (or is greater than) the amplitude of the sum antenna signal, the reply is not accepted, and the Test Set displays a "Fault=Angle" message. The system works equally well in screening interrogations received outside the main (sum antenna) beam in interrogator test mode.

If a transponder passes a TS-4530/UPM test, the following conditions have been acceptable:

- A. TS-4530/UPM interrogations were accepted by the transponder. Transponder replies to TS-4530/UPM interrogations were not suppressed by reception of the radiated SLS signal. Therefore, the transponder was located near the center of the TS-4530/UPM's sub-antenna beam and no adjacent objects reflected the SLS to the transponder antenna.
- B. Transponder replies were accepted by the TS-4530/UPM. Therefore, the reply signal was received from the direction the unit was aimed and excessive reflection levels of the transponder signal were not detected.

If the Test Set is poorly aimed, the test environment is reflective, or a surrounding transponder interfered with the test, the TS-4530 will not pass the transponder because one of the following occurred:

- A. The transponder saw the Test Set's SLS pulse and did not reply. This could result from improper aiming of the Test Set, or a strong reflection of the Test Set's signal. The Test Set will indicate a transponder failure for low or no replies.

- B. The transponder correctly observed the Test Set's interrogation and replied, but the Test Set observed excessive signal power from other than the direction the Test Set was aimed. This could be due to reflection of the transponder signal, or due to a reply from a second transponder not within the Test Set's target area. The Test Set will indicate this by displaying the message "FAULT=ANGLE".

If the message "FAULT=ANGLE" occurs, the Test Set operator should change position relative to the aircraft antenna, or attempt to move the location of reflective objects near the aircraft. If a fail with "no replies" or "low replies" occurs, the operator should change position and / or move closer to the aircraft antenna to determine if there is multipath or if there was a problem with the transponder being tested.

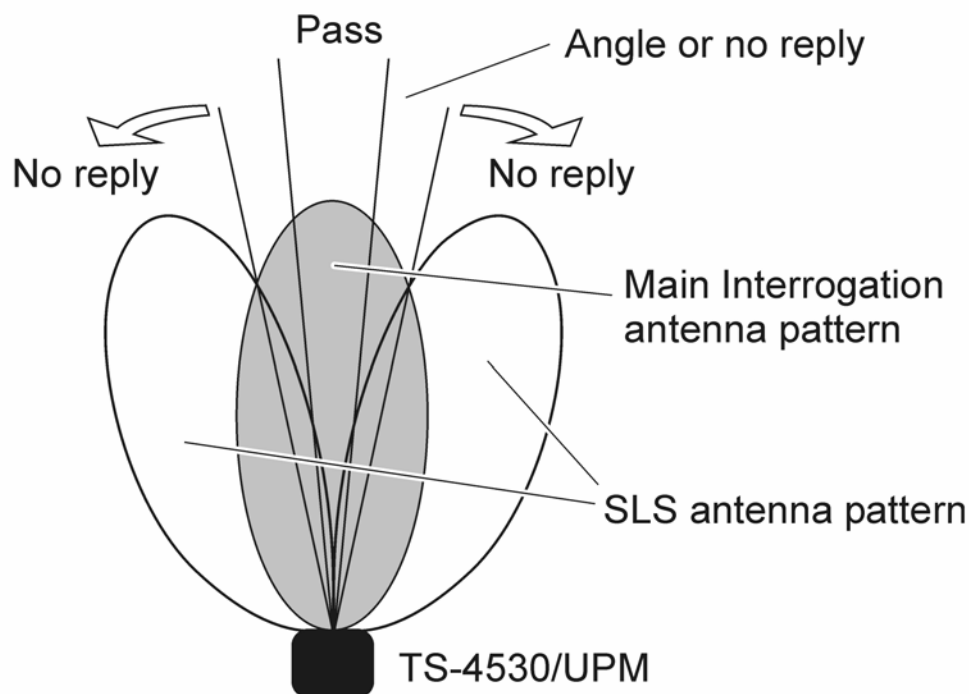

Figure 3-2. Antenna Patterns

MTL MEASUREMENT METHOD

Minimum Triggering Level (MTL) is normally defined as the transponder's input signal level required to achieve 90% reply rate. When testing in an over-the-air test environment, there is the possibility of replies lost to interference or ambient noise, which can produce MTL measurement errors. Minimizing the number of interrogations during the test is desired to limit Mode 4 code exposure and reduce interference to other systems. With a limited number of samples, missing one pulse makes a significant difference in the reply percentage as the reply rate is effectively averaged by the number of samples.

In the presence of interference, the test signal received by the transponder may need to be significantly above MTL to keep the replies lost to interference below 10%. The solution to this situation is to reduce the reply threshold to around 80%. This allows twice as many errors, reducing the effects of interference and the limited averaging. In the absence of interference, the measured MTL will be slightly low, but typical transponders rapidly transition from 90% to 10% replies in a 1 to 2 dB window.

The TS-4530/UPM method for determining a transponder's MTL is to repeatedly interrogate the UUT with bursts of 12, adjusting the level of each burst until the transponder responds with 10 replies (10-of-12 replies corresponds to a reply percentage of 83%). The process of MTL measurement begins with the first burst of 12 TS-4530/UPM interrogations at the lowest transmit level, corresponding to a test distance of approximately 4 feet. Should the transponder respond with less than 10 replies, the burst is repeated at a transmit level 6 dB higher. The process is repeated until 10 or more replies are received or the maximum level corresponding to a test distance >250 feet is reached. Once communication with the transponder has been established, the generator level is reduced in 1 dB steps until the reply rate falls back below the 10-to-12 threshold, establishing the MTL within a resolution of 1 dB. The MTL is further resolved by increasing the burst levels in ¼ dB steps until the 10-of-12 reply is re-established. Now that the transponder's MTL has been determined, the TS-44530/UPM transmit level is increased to a level 3 dB above the MTL where % SLS reply, and other measurements are performed.

INTERROGATOR TARGET OPERATION

The user has the option to perform interrogator testing in either single or multi-target mode. As most modern interrogator systems are equipped with a display, the multi-target mode allows for quick verification of target recognition in the presence of other traffic. Multi-target replies are generated at 4, 8, 16, 32, 128, and 256 nmi. Doubling the range of each consecutive target results in a 6 dB drop in level between replies. The target grouping allows for automatic verification of time-controlled, gain circuits within the interrogator. All targets will present the same code and altitude. In single target mode, one reply is generated at a distance of 4 nmi. The user may select a normal, identification, or emergency reply type (Normal replies only are transmitted in multi-target mode.).

EXTERNAL BATTERY CHARGER/DISCHARGER (PN: 01-1045-10)

NOTE

The external battery charger/discharger is for indoor use only. Do not expose charger or AC adapter to rain or moisture.

The external battery charger / discharger is powered from 12 volts supplied by the AC adapter. This charger must only be operated from a 12 volt dc source. Battery sticks should not be left in the charger for extended periods (over 30 days) when not in use, as there is a small amount of discharge due to the battery voltage sensing circuits within the charger, which could result in excessively deep discharge and battery damage if stored for several months. The battery charger may be left plugged in when inserting and removing batteries, but it is recommended to unplug the AC adapter when it is not in use.

WARNING

Do not attempt to charge any batteries other than the supplied battery sticks or commercial C-size NI-CAD or NiMH batteries. This could result in battery explosion and cause injury or death.

NOTE

Battery sticks should not be left in the charger for an extended period of time (over 30 days) when not in use, as there is a small amount of discharge due to the battery voltage sensing circuits within the charger, which could result in excessively deep discharge and battery damage if stored for several months.

Battery Charging

The 12 Volt input from the AC adapter powers a 1.5 amp constant current source for charging the battery. The current source is controlled by an integrated circuit that checks for the presence of a battery, limits the charging temperature range, and terminates charging when the battery is fully charged. The IC determines that a battery is fully charged by detecting the small drop in battery voltage which occurs once the NiCad or NiMH batteries are fully charged by constant current. Charging is terminated if excessive battery temperature is detected. Operation of the charger is inhibited when the discharge cycle is active.

Battery Discharging

The discharge load resistor is switched by a control circuit that monitors the battery voltage under load. Discharge is initiated by the front panel switch and is maintained until the battery voltage drops under 6 volts (1 volt per cell). This provides nearly complete discharge without discharging to the point of potential battery damage. The discharge circuitry is battery powered, so connection to the AC adapter is not required. If the AC adapter is connected, the charge cycle will begin automatically once the batteries are fully discharged. This allows a partially discharged battery to automatically be fully discharged then charged, preventing NiCad memory effects. If the AC adapter is not connected, battery discharging will terminate automatically once completed.

END OF WORK PACKAGE

TM 43-6625-916-12

CHAPTER 2

OPERATOR INSTRUCTIONS

CHAPTER 2 INDEX

WP Sequence No.

DESCRIPTION AND USE OF CONTROLS AND INDICATORS	0004 00
Operator's Controls and Indicators.....	0004 00-1
Location of Test Set Controls, Indicators, and Connectors (Figure 4-1).....	0004 00-1
Test Set Controls, Indicators, and Connectors (Table 4-1).....	0004 00-2
Test Set Display Indicators (Figure 4-2).....	0004 00-3
Test Set Display Indicators (Table 4-2).....	0004 00-3
ASSEMBLY AND PREPARATION FOR USE	0005 00
General	0005 00-1
Battery Stick Installation	0005 00-1
Test Set Battery Stick Installation (Figure 5-1).....	0005 00-2
Perform BIT Test and Display Check	0005 00-2
Save Direct Connect Cable Cal Factor.....	0005 00-3
External Power Supply Operation	0005 00-4
Transponder Mode 4 Programming Procedure.....	0005 00-5
KIR-1C Mode Programming Set-up Diagram (Figure 5-2).....	0005 00-6
Preparation for Mode 4 Interrogator Procedure	0005 00-7
OPERATION UNDER USUAL CONDITIONS	0006 00
6-1 Test Set Modes of Operation	0006 00-1
6-2 Test Overview of the TS-4530/UPM Operation	0006 00-1
6-2.1 Menu Structure Chart.....	0006 00-1
6-2.2 Test Overview	0006 00-1
6-3 Test Set Modes of Operation	0006 00-1
Menu Structure Chart (Figure 6-1).....	0006 00-2
6-4 Direct Connect Test Operation	0006 00-2
Direct Connect Mode Operation (Figure 6-2)	0006 00-3
6-5 Radiated (Over the Air) Test Operation	0006 00-3
6-6 Transponder Testing.....	0006 00-4
Transponder Testing Setup Procedures (Table 6-1).....	0006 00-5
6-6.1 Transponder Manual Tests	0006 00-6
Transponder Manual Tests (Table 6-2).....	0006 00-6
6-6.2 Transponder Automatic Tests	0006 00-7
Transponder Automatic Tests (Table 6-3).....	0006 00-7
6-6.3 Transponder Zeroize Mode 4 Codes	0006 00-8
Transponder Zeroize Mode 4 Code Procedures (Table 6-4)	0006 00-8
6-6.4 Transponder Load New Mode 4 Codes.....	0006 00-8
Transponder Load New Mode 4 Code Procedures (Table 6-5)	0006 00-8
6-7 Interrogator Testing.....	0006 00-10
Interrogator/TCAS Testing Setup Procedures (Table 6-6).....	0006 00-11
6-7.1 Interrogator Manual Tests.....	0006 00-12
Interrogator/TCAS Manual Tests (Table 6-7)	0006 00-12
6-7.2 Interrogator Sensitivity Tests	0006 00-14
Interrogator/TCAS Sensitivity Tests (Table 6-8).....	0006 00-14
6-7.3 Interrogator Automatic Tests.....	0006 00-14
Interrogator/TCAS Automatic Tests (Table 6-9).....	0006 00-14
6-7.4 Interrogator/TCAS Test Scenario.....	0006 00-15
Interrogator Test Scenario? (Table 6-10)	0006 00-15
6-8 General Requirements and Setup for TCAS Testing.....	0006 00-16

CHAPTER 2 INDEX - Continued

6-9 Platform Testing Problems 0006 00-17
Platform Testing Problem Chart (Table 6-11) 0006 00-17

6-10 Test Set Shutdown 0006 00-18

6-11 Test Set Operation Instructions Decal 0006 00-18
Test Set Operation Instructions Decal (Figure 6-3) 0006 00-19

6-12 Test Set Battery Removal Warning Label 0006 00-20
Test Set Battery Removal Warning Label (Figure 6-4) 0006 00-20

BATTERY CHARGING AND DISCHARGING0007 00

Battery Charging Instructions Using Internal Battery Charger and External Power Supply ... 0007 00-1
Internal Battery Charger Operation..... 0007 00-1

Battery Charging Instructions Using External Battery Charger/Discharger 0007 00-2
Operator's Controls and Indicators 0007 00-2
Location of Battery Charger Controls, Indicators, and Connectors (Figure 7-1) 0007 00-2
Battery Charger Controls, Indicators, and Connectors (Table 7-1) 0007 00-3
Battery Charging Using External Charger/Discharger 0007 00-3
Battery Discharging Using External Charger/Discharger 0007 00-4
To Refresh Battery Using External Charger/Discharger..... 0007 00-4

BENCH UTILITY0008 00

Introduction..... 0008 00-1
Installation 0008 00-1
Operation..... 0008 00-2
Test Manager Panel (Figure 8-1) 0008 00-2
Maintenance Panel (Figure 8-2)..... 0008 00-3

OPERATION UNDER UNUSUAL CONDITIONS.....0009 00

Emergency Commercial C-Size Battery Installation 0009 00-1
Battery Compatibility Chart (Table 9-1) 0009 00-1
Test Set Emergency Commercial C-Size Battery Installation (Figure 9-1) 0009 00-2

OPERATOR'S CONTROLS AND INDICATORS

Figure 4-1 illustrates and locates all controls, indicators, and connectors. Table 4-1 identifies and describes the function of controls, indicators, and connectors of the Test Set.

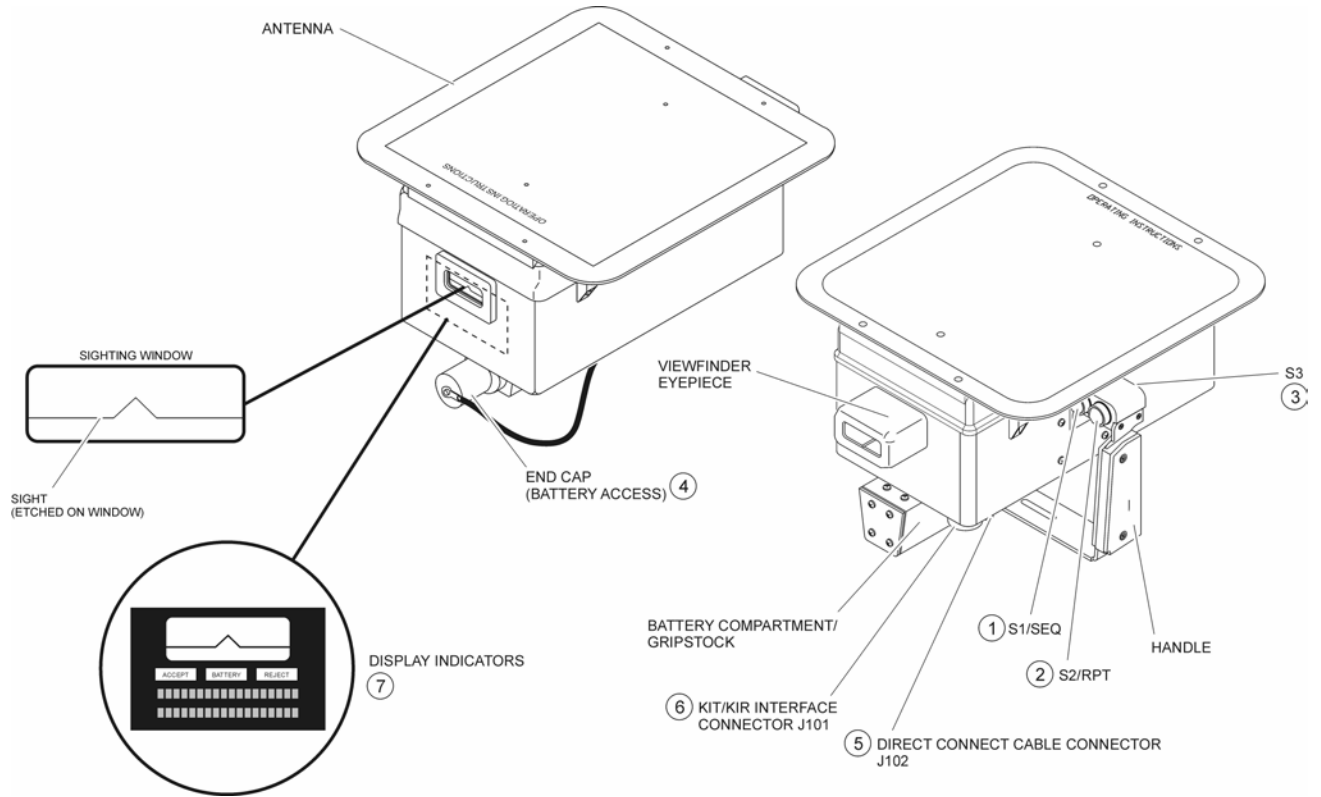

Figure 4-1. Location of Test Set Controls, Indicators, and Connectors

Table 4-1. Test Set Controls, Indicators, and Connectors

Key	Control, Indicators, or Connector	Function
1	S1/SEQ (BIT Test)	From the SETUP/FUNCTIONS menu structure, S1 initiates the Display Check followed by the BIT test.
	S1/SEQ (Setup)	From the SETUP/FUNCTIONS menu structure, S1 allows the operator to sequence through Test Set default setup values such as distance, altitude, target, and Mode 4 verification.
	S1/SEQ (Transponder)	From the "Device to Test Transponder" screen, S1 allows the operator to sequence through the various test modes during manual testing. In automatic testing, S1 initiates testing of all formats with the speed and convenience advantage of a single button push (S1). S1 can be held for 3 seconds to move backwards through the menu items.
	S1/SEQ (Interrogator)	From the "Device to Test Interrogator" screen, S1 allows the operator to sequence through the various test modes during manual testing. In automatic testing, S1 initiates testing of all formats with the speed and convenience advantage of a single button push (S1). S1 also initiates the MDL test for sensitivity. For inter test Scenario, S1 sequences through ATCRBS checks such as level, dive, climb, above, and Mode S level. S1 can be held for 3 seconds to move backwards through the menu items.
2	S2/RPT	The function of the S2 button is dependent on the displayed screen type. Pressing this button at a user prompt screen is done to indicate a No/False response to a question and to advance to the next option. In manual test mode, momentarily pushing S2 repeats the last test. Pushing S2 for 3 seconds in any transponder screen brings up the temporary transponder setup screen. Pushing S2 for 3 seconds in any interrogator screen brings up the temporary interrogator setup screen.
3	S3	Holding down the S3 button for three seconds from any screen returns the unit to the main/power-on screen. A number of parametric results are available when operating the Test Set in manual test mode which are not available in auto test mode. These parametrics are accessed by momentarily pushing S3 from any manual-mode test results screen.
4	END CAP	The end cap secures and makes contact with battery stick or standard C-size NI-CAD, NiMH, or alkaline batteries.
5	DIRECT CONNECT CABLE CONNECTOR, J102	Used to connect the direct connect port of the test set to the unit under test. Direct connect testing aids in troubleshooting IFF systems (eliminates antenna, antenna cabling, and lobing switch, if used). Also, direct connect testing may avoid Test Set interference with nearby active IFF systems or reception of unwanted replies from nearby transponders.
6	KIT/KIR INTERFACE CONNECTOR, J101	I/O interface to COMSEC computers, TS-4530/UPM RS-232 port, and DC power.
7	DISPLAY INDICATORS	Figure 4-2 shows the operator view as seen looking through the viewfinder. Table 4-2 describes the function of the display indicators.

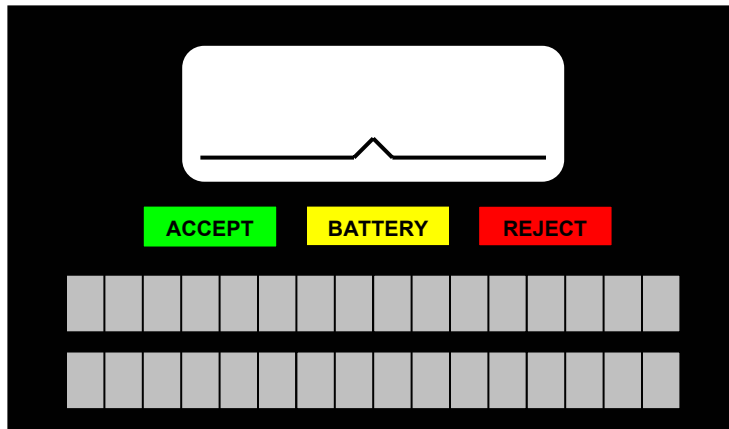

Figure 4-2. Test Set Display Indicators

Table 4-2. Test Set Display Indicators

Indicator	Function
Alphanumeric Display	A two row by 16 character display provides operating prompts and test results
ACCEPT	Illuminates (green) when transponder / interrogator transmission is correct.
BATTERY	Illuminates (yellow) when battery power is less than 20% and flashes slowly when battery power is less than 5%.
REJECT	Illuminates (red) when transponder / interrogator transmission is incorrect.

END OF WORK PACKAGE

GENERAL

Before you use the TS-4530/UPM, perform the following procedures.

- a. Press RELIEF VALVE on transit case cover to release any internal pressure.
- b. Release the five case latches and open the transit case cover.
- c. Check TS-4530/UPM for completeness against equipment listed in WP0002 00.

WARNING

Do not short positive and negative terminals together when handling NI-CAD batteries. If you short the battery terminals, the battery cells may EXPLODE and cause you INJURY or DEATH.

- d. Visually inspect all items for any damage. If damage is visible, refer to Preventive Maintenance Checks and Services (WP0024 00).

NOTE

When regularly using the Test Set, be sure you keep both battery sticks fully charged. This will provide a charged, spare battery stick to maintain continuous Test Set operation. If the battery stick is to be stored for more than 30 days, it should be discharged prior to storage to maximize storage life.

- e. Charge battery stick (WP0007 00).

NOTE

If a battery stick is not available, NI-CAD or NiMH rechargeable C-size batteries or C-size alkaline batteries may be substituted. Do not substitute with carbon-type batteries. Carbon-type batteries are not capable of supplying required current during interrogation portion of Test Set test cycle due to high internal resistance. Refer to WP0008 00 for details on battery substitution.

BATTERY STICK INSTALLATION

Install battery stick as follows:

WARNING

Do not short positive and negative terminals together when handling NI-CAD batteries. If you short the battery terminals, the battery cells may EXPLODE and cause you INJURY or DEATH.

NOTE

You will not damage the Test Set if battery stick is inserted so that the polarity is incorrect, but Test Set will not operate until battery stick is correctly installed.

- a. Remove battery compartment end cap (Figure 5-1) and install a fully charged battery stick. Insert positive terminal of the battery stick first (i.e., toward Test Set eyepiece).
- b. Install end cap and tighten snugly.
- c. Perform BIT TEST AND DISPLAY CHECK.

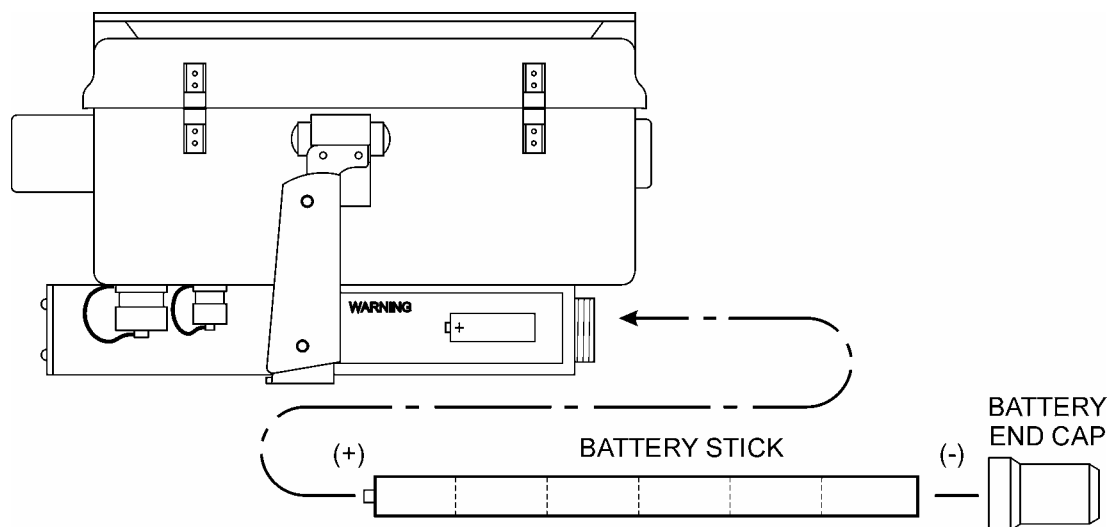

Figure 5-1. Test Set Battery Stick Installation

PERFORM BIT TEST AND DISPLAY CHECK

NOTE

Do not aim Test Set at an active IFF antenna during this procedure.

- a. Aim the Test Set toward the ground or away from an active IFF antenna.
- b. Observe display through Test Set eyepiece.
- c. If the display is illuminated, proceed to step d. If not, press any Test Set button to bring the unit out of the standby mode.

NOTE

If Test Set does not operate when pushing any button, the battery stick is too discharged and needs charging.

- d. Execute the BIT test function. From the "Device to test Transponder" screen, press S2, S2, S1, and S1 (to sequence to and initiate the BIT test). Refer to the antenna decal (Figure 6-3, WP00006 00).
- e. Testing of the unit display is the first function performed during the BIT sequence. Verify the display illuminates all elements.

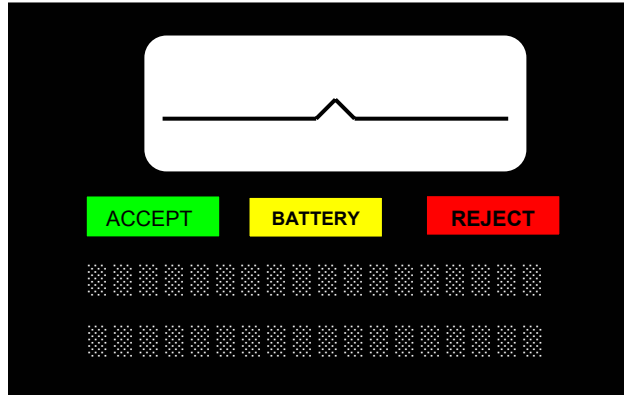

- f. Verify the Test Set display “BIT Test: PASS” at the end of the BIT sequence. If a problem with the Test Set operation is indicated by “BIT Test: FAIL”, refer to Troubleshooting Section TS007 (WP0017 00). If the “BIT Test: PASS” screen is displayed, the Test Set is ready for use.

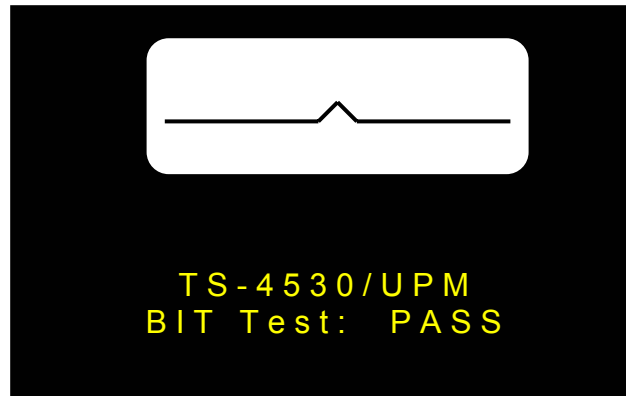

SAVE DIRECT CONNECT CABLE CAL FACTOR.

NOTE

To improve measurement accuracy during direct connect testing, the Test Set can compensate for the loss of the direct connect cable. The direct connect cable loss is marked on a tag attached to the cable. The cable cal factor is stored in the Test Set even when the battery is removed.

To initially store the cable cal factor in a new Test Set or update the cal factor if the direct cable is replaced, utilize the bench utility (PN: 60-0694-B2). The cable cal factor is marked on the tag attached to the direct connect cable. Refer to WP0008 00 utilizing the bench utility for downloading and viewing the direct connect cable cal factor in the Test Set.

EXTERNAL POWER SUPPLY OPERATION

The Test Set will operate from an external DC source using the supplied DC power cable (PN: 55-1054-14) or from the supplied AC Adapter (PN: 15-0360-M0). The battery stick does not have to be removed, but can be during external power supply operation.



Alkaline non-rechargeable batteries must be removed before using external power.

AC Source. If operation using the AC Adapter (PN: 15-0360-M0) is desired, connect as follows:

- a. Connect KIT/KIR-1C interface cable (PN: 15-1045-10) to Test Set.
- b. Connect AC Adapter to KIT/KIR-1C interface cable.
- c. Connect AC Adapter to 100 to 240 V ac, 50 to 400 Hz power.



The AC Adapter is intended for indoor use only.

- d. Perform the BIT TEST AND DISPLAY CHECK.

DC Source. If operation using an external DC source is desired, connect as follows:

- a. Connect KIT/KIR-1C interface cable (PN: 55-1045-10) to Test Set.
- b. Connect the DC Power Cable (PN: 55-1045-14) to the KIT/KIR-1C interface cable.
- c. Connect DC Power Supply banana plugs to an external +12 to +28 VDC power supply. Ensure proper polarity when connecting banana plugs.

NOTE

The external DC source must provide 12 to 28 V dc and be capable of supplying at least 25 watts (2 amps at 12V or 1 amp at 28V).

- d. To check for proper display function, perform the BIT Test. From the SETUP/FUNCTIONS menu structure, pressing S1 twice initiates the Display Check followed by the BIT test. The Display Check illuminates all display elements in the following screen for approximately five seconds. If the Display Check display fails, go to Troubleshooting Section TS005 (WP0015 00).

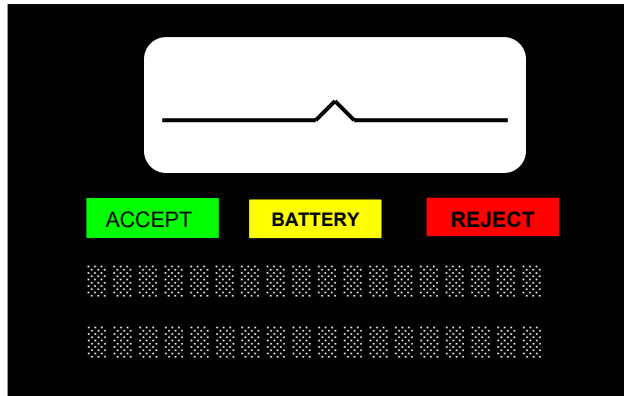

TRANSPONDER MODE 4 PROGRAMMING PROCEDURE

NOTE

The code loading process does not load the code of the day keys into the Test Set. A sampling of 12 mode 4 interrogations is stored for each code: A, B, Verify A, and Verify B. A Test Set which has been "Code Loaded" is not a secure device. Code samples in the Test Set should be zeroized when no longer required for testing to help prevent accidental use of the incorrect day's code.

- a. To program the Test Set memory with appropriate mode 4 codes of the day (A, B, verify A, verify B) using the model KIR-1C COMSEC device, proceed as follows:
 - (1) Connect the KIT/KIR-1C interface cable (PN: 55-1045-10) between the KIR-1C COMSEC device and the Test Set as shown in Figure 5-2.
 - (2) Connect KIR-1C COMSEC device. Load key into COMSEC device.

NOTE

The internal battery of the COMSEC device must be installed in order to operate properly with the Test Set.

- (3) Code loading can occur in the following ways:
 - If the operator does initial power up by inserting the battery or applying external power, the Test Set autodetects COMSEC and loads the code.
 - Otherwise the operator can press buttons to go through the menus to load the codes. Refer to paragraph 6-6.4.

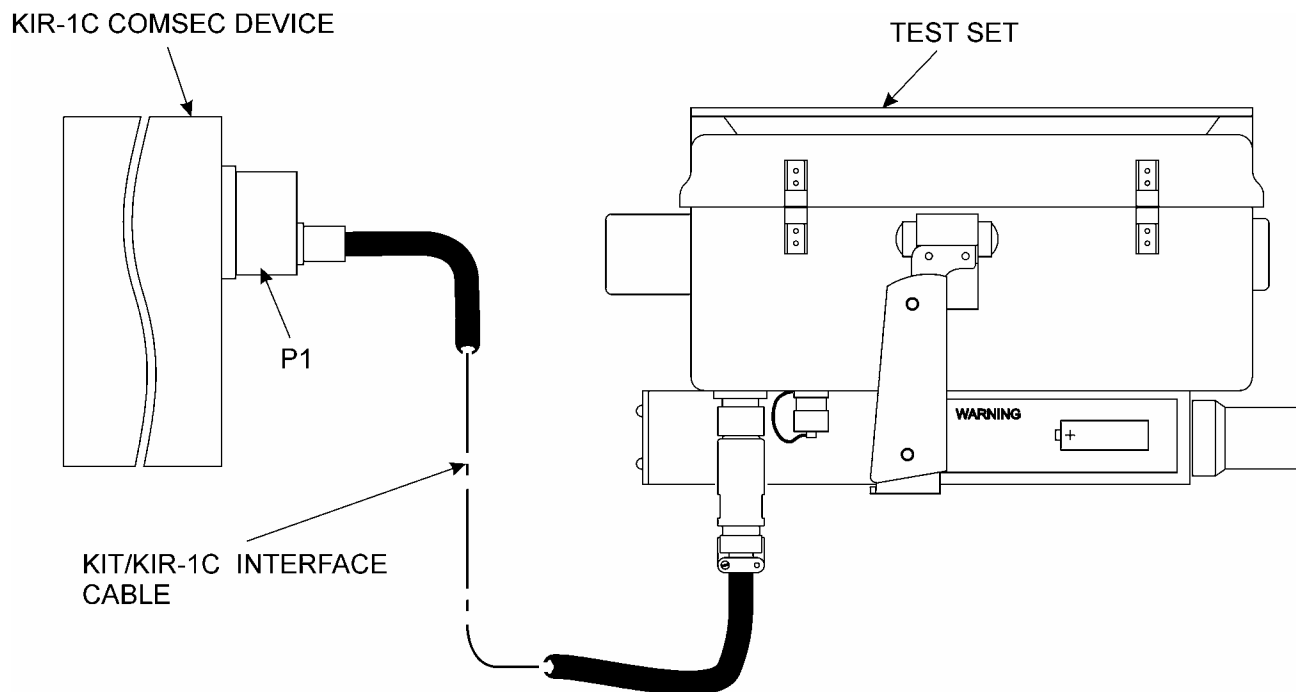
**NOTE**

Power is supplied to the KIT/KIR-1C by the Test Set via the KIT/KIR-1C interface cable. The KIT/KIR-1A requires more power than the Test Set can supply and is not compatible with the KIT/KIR-1C cable. The KIT/KIR-1A cable (not part of COEI) does not provide power from the Test Set and must be connected to 115 V ac using the attached cord and plug (P204, not shown).

Figure 5-2. KIR-1C Mode 4 Programming Set-up Diagram

WARNING

After codes are loaded into the Test Set, the COMSEC device will retain the key information. Press the ZEROIZE button on the front of the KIR-1C to clear its codes when testing is completed.

- (4) After the codes are loaded into the Test Set, disconnect the KIR-1C COMSEC device and the KIT/KIR-1C interface cable. The Test Set is now ready to test transponders.

b. Mode 4 Zeroize Procedure

The zeroize process erases the Mode 4 challenge video samples stored in the Test Set. Zeroize does not clear the key from any attached COMSEC. The COMSEC may be manually zeroized by pressing its zeroize button on the front panel. To zeroize the Test Set go to the zeroize screen (WP0006 00, Figure 6-1) and push S1.

PREPARATION FOR MODE 4 INTERROGATOR PROCEDURE

- a. The KIT-1C must be connected to the Test Set at all times during Mode 4 interrogator testing.

NOTE

The internal battery of the COMSEC device must be installed in order to operate properly with the Test Set.

- b. Once the Test Set and keyed KIT-1C are connected via the KIT/KIR-1C cable, Mode 4 interrogator testing may begin.

NOTE

After interrogator testing is completed, the COMSEC device may retain the key information.

- c. Mode 4 Zeroize Procedure

The COMSEC must be zeroized by pressing its zeroize button on the front panel.

END OF WORK PACKAGE

6-1 TEST SET MODES OF OPERATION

The Radar Test Set TS-4530/UPM operates in two modes of operation:

- Direct Connect Test Operation
- Radiated (or over the air) Test Operation

6-2 TEST OVERVIEW OF THE TS-4530/UPM OPERATION

6-2.1 Menu Structure Chart. There are three menu navigation routes (see Figure 6-1) in the menu:

- SETUP/FUNCTIONS of the Test Set
- TEST XPDR (Transponder Testing)
- TEST INTR (Interrogator or TCAS Testing)

6-2.2 Test Overview. The following is a test overview when using the TS-4530/UPM. More detailed operating procedures follow this overview of the testing sequencing steps.

a. TRANSPONDER

- Insert battery.
- Load Mode 4.
- Prepare UUT IAW applicable aircraft TM.
- Setup or verify parameters in the Test Set.
- Perform tests (either manual or automatic).
- Store results (if desired)
- Download and view/print stored results with the bench utility (if desired).

b. INTERROGATOR OR TCAS

- Insert battery.
- Prepare UUT IAW applicable TM.
- Connect KIT/KIR-1C cable and COMSEC (KIT-1C) device if testing Mode 4.
- Setup or verify parameters in the Test Set.
- Perform tests (either manual or automatic).
- Store results (if desired).
- Perform sensitivity test.
- Perform scenario test if interrogator or TCAS has display system.
- Download and view/print stored results with the bench utility (if desired).

6-3 TEST SET MODES OF OPERATION

Refer to the Menu Structure Chart (Figure 6-1) when performing Direct Connect (paragraph 6-4) or Radiated (paragraph 6-5) test operation procedures.

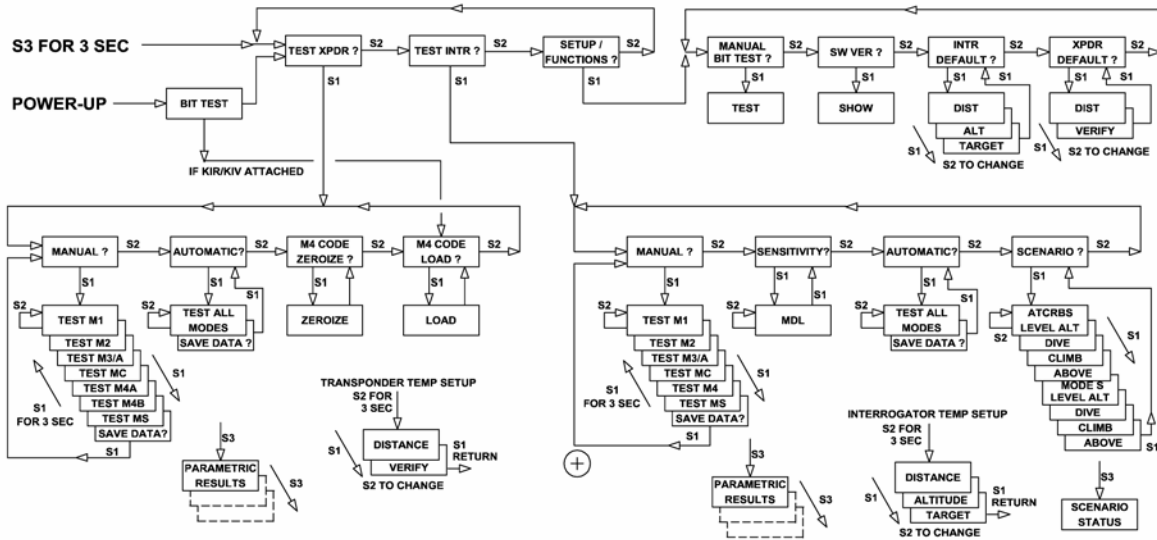

Figure 6-1. Menu Structure Chart

6-4 DIRECT CONNECT TEST OPERATION

- a. In direct connect test mode, the Test Set is connected directly to the unit under test. (See Figure 6-2.) This is accomplished using the direct connect RF cable (PN: 55-1045-11) stored in the transit case. Connect one end to the Test Set direct connect cable connector (J1) and the other end to the UUT.

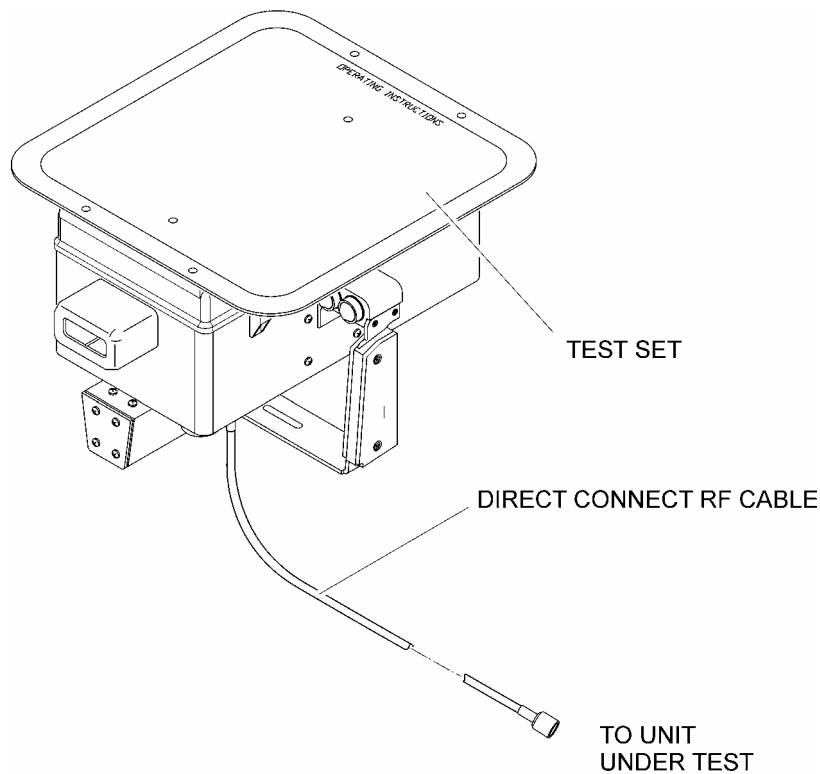

Figure 6-2. Direct Connect Mode Operation

- b. Energize the IFF system to be tested.

NOTE

The Test Set will enter the standby mode if none of the control buttons have been pushed for 60 seconds (display will be off). Press any button to return the Test Set to the active state.

- c. Press any button to bring the Test Set out of standby mode to active mode or apply power to the Test Set.
- d. Press and hold the S3 button for 3 seconds at any time to select a different test mode (transponder/interrogator/setup).
- e. Initiate Transponder (Paragraph 6-6) or Interrogator (Paragraph 6-7) testing.

6-5. RADIATED (OVER THE AIR) TEST OPERATION

- a. Energize the IFF system to be tested.
- b. Position the Test Set at an appropriate distance from the aircraft antenna. Transponder test range is from 10 to 150 feet (3.1 to 46.1 m). Interrogator test range is from 30 to 70 feet (9.3 to 21.5 m). Aim at the aircraft's antenna through the Test Set viewfinder.

NOTE

The Test Set will enter the standby mode if none of the control buttons have been pushed for 60 seconds (display will be off). Press any button to return the Test Set to the active state.

- c. Press any button to bring the Test Set out of standby mode to active mode or apply power to the Test Set.

NOTE

If the Test Set is in standby mode, pushing any button will bring it to the previous power on condition.

- d. Press and hold the S3 button for 3 seconds at any time to select a different test mode (transponder/interrogator/setup).
- e. If mode 4 transponder testing is desired the code load function must be executed prior to testing. Code loading is described in WP0005 00 (TRANSPONDER MODE 4 PROGRAMMING PROCEDURE).
- f. Interrogator testing may or may not require setting the Test Set to an appropriate altitude (platform dependant). The Test Set's altitude select screen is accessible after entering the interrogator test mode (See Menu Structure Chart, Figure 6-1). The altitude is incremented in 500 ft. steps by pushing the S2 button. Mode 4 interrogator testing requires a KIT-1C COMSEC device to be attached during the interrogator testing. Connect the KIT-1C COMSEC device and program the device with the correct code of the day. The KIT-1C COMSEC device may be disconnected at the conclusion of interrogator tests.
- g. If the message "FAULT = ANGLE" is displayed, excessive reflection was detected by the Test Set. Change positions and restart the test.
- h. After each test, check if the ACCEPT or REJECT indicator is illuminated. If the ACCEPT lamp is on, proceed to the next step. If the REJECT lamp is on, observe the displayed text to determine the FAULT source(s).
- i. Repeat all tests while aiming at the second antenna of the UUT (if equipped). If so equipped, both aircraft antennas must be tested for proper operation.
- j. Four intruder flight patterns are available for interrogator or TCAS testing. The intruder approach speed is fixed at 720 nmi/h, scenario starting distance is 15 nmi, ending distance is 0.5 nmi for ATCRBS and 0 nmi for Mode S. The intruder flight profile options are level, dive, climb, and above. The flight profiles are selected using the S1 control button. Dive, climb, and above intruder starting altitude is 5000 feet (1525 m) above or below the Test Set altitude set in step g. Intruder flight status (range and altitude) are accessed using the S3 button. The scenarios can be restarted or repeated at any time by pushing the S2 button.
- k. Initiate Transponder (Paragraph 6-6) or Interrogator (Paragraph 6-7) testing.

6-6. TRANSPONDER TESTING.**NOTE**

Mode S capable transponders operate differently dependent on the state of the aircraft in-air / on-ground status. It may not be possible to test all transponder operational modes without spoofing the on-ground condition to in-air, which may be impractical in some test situations. Refer to the appropriate platform equipment manuals for proper test conditions and expected results.

- a. Perform the initial setup (Table 6-1) of the Test Set. (Refer to Figure 6-1 for the flow chart of the menu structure).

b. Perform tests (either manual or automatic). There are four menu paths for transponder testing.

- Manual – Manual mode allows the operator to control the execution of individual test modes using the S1 sequence button. Tests can be repeated by pressing S2.
- Automatic – The Automatic mode provides testing of all formats with the speed and convenience advantage of a single button push (S1). Pushing S2 will repeat the test in its entirety.
- Zeroize Mode 4 Codes – This mode provides the operator with either a YES or NO options for Zeroing the Mode 4 Code for the day.
- Load New Mode 4 Codes? – This mode provides for code loading.
-

NOTE

To abort changes during setup, the operator may press S3 for 3 seconds before accepting last selection.

Table 6-1. Transponder Testing Setup Procedures

STEP	BUTTONS PRESSED	RESULTS/REMARKS
From the “Device to test Transponder” screen, go to the TEST SET SETUP/FUNCTIONS screen.	<p align="center">NOTE</p> <p>It may be necessary to press S2 to navigate to the appropriate transponder test menu screen because the Test Set retains the previous state of the last test or action performed.</p> <p>Press S2, S2</p>	SETUP/FUNCTIONS screen.
Go to the TRANSPONDER DEFAULT setup screen.	Press S1, S2, S2, S2	<p>Transponder Default Setup.</p> <p>From this screen, the distance default setting and the verify mode 4 default setting is selected.</p>
(a) Set the distance default setting.	Press S2 to change current selection. Press S1 to accept current selection and continue.	The distance default setting screen changes in 10 ft increments (range is 10 ft to 150 ft.) Press S2 until desired distance default setting is reached.
(b) Once the distance default setting is selected, go to the MODE 4 VERIFY screen.	Press S2 to change current selection. Press S1 to accept current selection and continue.	<p>The MODE 4 VERIFY setting is either ON or OFF.</p> <p>Pressing S2 toggles between the ON and OFF settings.</p>
(c) When all default settings are selected, return to the “Device to test Transponder” screen.	Press S3 for three seconds. Then press S2 to return to manual selection screen.	<p>From the TRANSPONER DEFAULT setup screen, pressing S2 will show the BIT test screen. Pressing S3 for three seconds will return to the SETUP/FUNCTIONS screen.</p> <p>After obtaining the SETUP/FUNCTIONS screen, pressing S2 will return to the “Device to test Transponder” screen.</p>

6-6.1 Transponder Manual Tests (Refer to Table 6-2).

NOTE

If mode 4 transponder testing is desired, the code load function must be executed prior to testing. Code loading is described in WP0005 00 (MODE 4 PROGRAMMING PROCEDURE).

Table 6-2. Transponder Manual Tests

STEP	BUTTONS PRESSED	RESULTS/REMARKS
From the "Device to test Transponder" screen, go to the "XPDR Test Manual?" screen.	<p align="center">NOTE</p> <p>It may be necessary to press S2 to navigate to the appropriate transponder test menu screen because the Test Set retains the previous state of the last test or action performed.</p> <p>Press S1.</p>	"XPDR Test Manual?" screen is displayed.
From the "XPDR Test Manual?" screen, go to Mode 1.	Press S1.	<p>In Direct Connect mode, "Mode 1 ...Direct...." screen is shown for the Mode 1 testing.</p> <p>In Radiated mode, "Mode 1XX ft." screen is shown for the Mode 1 testing.</p> <p>Tests can be repeated by pressing S2.</p> <p>The operator can go to the Transponder Temp Setup by pressing S2 for at least 3 seconds and releasing.</p> <p>The operator can view parametric data by pressing S3. Subsequent pushes of S3 display additional parametric screens, ultimately cycling back to the first page.</p>
Continue to sequence through the individual test modes (M2, M3, MC, Mode 4A(1), Mode 4B(1), and Mode S).	Press S1 to go through each mode.	The operator can back up to a previous test in the sequence by holding down the S1 button for at least 3 seconds and releasing.
Store results (if desired).	Pressing the S1 button when all formats are completed at the end of testing provides the "Save Test Data?" screen. This screen provides YES and NO options. The S2 button then serves as a toggle switch between YES and NO. Press S1 to execute.	Once the test sequence has been completed, the operator is given the option to save the test data to memory. If saved, the test number is displayed. In order to correlate the test results with the test aircraft the operator must record the test number and aircraft tail number. The data can be downloaded to a PC when testing has been completed.
If desired, download and view/print stored results using the bench utility (WP0008 00).	Go to WP0008 00.	

6-6.2 Transponder Automatic Tests (Refer to Table 6-3.)

Table 6-3. Transponder Automatic Tests

STEP	BUTTONS PRESSED	RESULTS/REMARKS
From the "Device to test Transponder" screen, go to the "XPDR Test Automatic?" screen.	<p style="text-align: center;">NOTE</p> <p>It may be necessary to press S2 to navigate to the appropriate transponder test menu screen because the Test Set retains the previous state of the last test or action performed.</p> <p>Press S1, S2.</p>	"Xpdr Test Automatic?" screen appears.
From the "Xpdr Test Automatic?" screen, start the testing in the Automatic Mode.	Press S1.	<p>Automatic mode provides testing of all transponder formats with the speed and convenience advantage of a single button push (S1). Pushing S2 will repeat the test in its entirety.</p> <p>The operator can go to the Transponder Temp Setup by pressing S2 for at least 3 seconds and releasing.</p>
Store results (if desired).	<p>Pressing the S1 button when all formats are completed at the end of testing provides the "Save Test Data?" screen. This screen provides YES and NO options.</p> <p>The S2 button then serves as a toggle switch between YES and NO.</p>	Once the test sequence has been completed, the operator is given the option to save the test data to memory. If saved, the test number is displayed. In order to correlate the test results with the test aircraft the operator must record the test number and aircraft tail number. The data can be downloaded to a PC when testing has been completed.
If desired, download and view/print stored results using the bench utility.	Go to WP0008 00.	

6-6.3 Transponder Zeroize Mode 4 Codes (Refer to Table 6-4.)

Table 6-4. Transponder Zeroize Mode 4 Code Procedures

STEP	BUTTONS PRESSED	RESULTS/REMARKS
From the "Device to test Transponder" screen, go to the "Zeroize Mode 4 Codes?" screen.	<p>NOTE</p> <p>It may be necessary to press S2 to navigate to the appropriate transponder test menu screen because the Test Set retains the previous state of the last test or action performed.</p> <p>Press S1, S2, S2.</p>	"Zeroize Mode 4 Codes?" screen appears.
From the "Zeroize Mode 4 Codes?" screen, go to the "Zeroize Codes Confirm?" screen.	<p>Press S1.</p> <p>If YES is selected, pressing S1 will zeroize codes.</p>	<p>The "Zeroize Codes Confirm?" screen appears providing two options (YES and NO). The S2 button then serves as a toggle switch between YES and NO.</p> <p>"Code of the day is zeroed" screen is momentarily displayed before returning to the "Zeroize Mode 4 Codes?" screen.</p>

6-6.4 Transponder Load New Mode 4 Codes (Refer to Table 6-5.)

Table 6-5. Transponder Mode 4 Code Loading Procedures

STEP	BUTTONS PRESSED	RESULTS/REMARKS
Connect the KIT/KIR-1C Interface Cable to the Test Set.		
Connect the KIR-1C COMSEC device to the KIT/KIR-1C Interface Cable.		KIR-1C must have its internal battery installed and should be "keyed" with correct codes.
From the "Device to test Transponder" screen, go to the "Load New Mode 4 Codes?" screen.	<p>NOTE</p> <p>It may be necessary to press S2 to navigate to the appropriate transponder test menu screen because the Test Set retains the previous state of the last test or action performed.</p> <p>Press S1, S2, S2, S2</p>	<p>The "Load New > Mode 4 Codes?" screen appears.</p> <p>NOTE</p> <p>Note the ">" symbol in the upper right of the Test Set display. This is a prompt to the operator that some operator action is required. It should appear on any display screen that requires the operator to push a button to take some action.</p>

Table 6-5. Transponder Mode 4 Code Loading Procedures - Continued

STEP	BUTTONS PRESSED	RESULTS/REMARKS
Press appropriate button (S1) to load codes.	Press S1.	The display says: (blank line) Code Load – PASS If it didn't work the display says: (blank line) Code Load – FAIL <p style="text-align: center;">NOTE</p> The PASS or FAIL message is only displayed for several seconds then it goes back to the screen that says "load new mode 4 codes". Therefore the operator needs to watch the display to make sure the code loaded properly.
	If the COMSEC was not connected or not detected, the display provides two options. <p style="text-align: center;">NOTE</p> Note the S2 button switches between RETRY & ABORT and the S1 button selects the desired option.	The display says: No COMSEC > Attached. RETRY? Or No COMSEC > Attached ABORT?
	If the COMSEC was not loaded properly or has a fault, the display provides two options. <p style="text-align: center;">NOTE</p> Note the S2 button switches between RETRY & ABORT and the S1 button selects the desired option.	The display says: No COMSEC Key! > Attached. RETRY? Or No COMSEC Key! > Attached ABORT?
	If the wrong type of COMSEC is connected (i.e. a KIT rather than a KIR) the display provides two options. <p style="text-align: center;">NOTE</p> Note the S2 button switches between RETRY & ABORT and the S1 button selects the desired option.	The display says: Invalid COMSEC > Attached. RETRY? Or Invalid COMSEC > Attached ABORT?

Table 6-5. Transponder Mode 4 Code Loading Procedures - Continued

STEP	BUTTONS PRESSED	RESULTS/REMARKS
	If the correct type of COMSEC was connected and loaded properly, the operator should be at the display that says: Load New > Mode 4 Codes?	The display says: Load New > Mode 4 Codes?
Disconnect the KIR-1C COMSEC device from the KIT/KIR-1C Interface Cable.		
Disconnect the KIT/KIR-1C Interface Cable from the Test Set.		NOTE From here, the Test Set is now ready to test Mode 4 transponders. The operator should press the appropriate buttons to continue or perform the transponder tests that they want to run.

6-7 INTERROGATOR TESTING.

The TS-4530 supports many interrogator types, and all features and tests may not be needed for some interrogators. Refer to the appropriate support manuals for the platform equipment for additional Test Setup information.

- Short range missile systems typically do not utilize target altitude or target type (identify, emergency) information, and the TS-4530 setup conditions for these parameters may be left in any position.
- Scenario tests are normally only used to test interrogator or TCAS (collision avoidance) systems with display units. Testing a TCAS system requires significant knowledge of the interaction of the TCAS with other aircraft systems, and requires spoofing of the aircraft on ground switch, radar altimeter, and barometric altitude systems to operate correctly during testing.

For Interrogator/TCAS Testing, perform the Test Set setup of Interrogator Default Setup. Setting the Test Set altitude may or may not be necessary depending on the platform under test.

- Perform the initial setup of the Test Set. (Refer to Figure 6-1 for the flow chart of the menu structure).

Table 6-6. Interrogator/TCAS Testing Setup Procedures

STEP	BUTTONS PRESSED	RESULTS/REMARKS
From the "Device to test Transponder" screen, go to the TEST SET SETUP/FUNCTIONS screen.	<p style="text-align: center;">NOTE</p> <p>It may be necessary to press S2 to navigate to the appropriate interrogator test menu screen because the Test Set retains the previous state of the last test or action performed.</p> <p>Press S2, S2</p>	SETUP/FUNCTIONS screen.
Go to the INTERROGATOR DEFAULT Setup" screen.	Press S1, S2, S2	<p>"Interrogator Default Setup" screen appears.</p> <p>From this screen, three default settings are selected:</p> <ul style="list-style-type: none"> • Distance? • Altitude? • Target?
(a) Set the distance default setting.	Press S1.	The distance default setting screen changes in 10 ft increments (range is 30 ft to 70 ft.) Press S2 until desired distance default setting is reached.
(b) Once the distance default setting is selected, go to the Altitude default screen.	Press S1.	The Altitude default setting screen range is 0 to 6000 ft. in 500 ft. increments, 12,000 ft., or 20,000 ft. Press S2 until desired distance default setting is reached.
(c) Once the Altitude default setting is selected, go to the Target default screen.	Press S1.	<p>The Target default setting has four options available:</p> <ul style="list-style-type: none"> • MULTI • IDENT • EMERG • SINGLE <p>Press S2 to cycle to the desired Target default setting.</p>
(d) When all default settings are selected, return to the "Device to test Transponder" screen.	Press S1. Then push S3 for three seconds. Then press S2.	<p>From the "Interrogator Default Setup" screen, pressing S2 once will show the TRANSPONDER DEFAULT setup screen.</p> <p>From the TRANSPONDER DEFAULT setup screen, pressing S2 again will show the BIT test screen. Pressing S3 for three seconds will return to the SETUP/FUNCTIONS screen.</p> <p>After obtaining the SETUP/FUNCTIONS screen, pressing S2 will return to the "Device to test Transponder" screen.</p>

- b. Perform tests (either manual or automatic). There are four menu paths for Interrogator testing.
 - Manual – Manual mode allows the operator to control the execution of individual test modes using the S1 sequence button. Tests can be repeated by pressing S2. The operator can back up to a previous test in the sequence by holding down the S1 button for three seconds. An additional manual-mode-only feature is the ability to view UUT parametric data. The operator gains entry to parametric screens by pressing the S3 button. Subsequent S3 pushes display additional parametric screens, ultimately cycling back to the first page.
 - Automatic – The Automatic mode provides testing of all formats with the speed and convenience advantage of a single button push (S1). Pushing S2 will repeat the test in its entirety.
 - Sensitivity – Pressing S1 initiates the MDL Test. Pressing S2 increases the Margin by 1 dB. Range is 0 dB to -12 dB.
 - Scenario - Pressing S1 sequences through ATCRBS level, dive, climb, above, and Mode S level, dive, climb, and above scenarios.

NOTE

Interrogator testing normally requires setting the Test Set to an appropriate altitude. The Test Set's altitude select screen is accessible after entering the interrogator test mode (See Menu Structure Chart, Figure 6-1.). A KIT-1C COMSEC device loaded with the code of the day must be attached to the Test Set during Mode 4 interrogator testing. Connect the KIT-1C as described in WP0005 00 and, unless already programmed, load the COMSEC with the code of the day. The KIT-1C may be disconnected at the conclusion of interrogator tests.

6-7.1 Interrogator Manual Tests (Refer to Table 6-7.)

Table 6-7. Interrogator/TCAS Manual Tests

STEP	BUTTONS PRESSED	RESULTS/REMARKS
From the "Device to test Transponder" screen, go to the "Inter Test Manual?" screen.	<p style="text-align: center;">NOTE</p> It may be necessary to press S2 to navigate to the appropriate interrogator test menu screen because the Test Set retains the previous state of the last test or action performed. Press S2, S1. Then press S2 the number of times necessary to cycle to the "Inter Test Manual?" screen.	"Inter Test Manual?" screen is displayed.

Table 6-7. Interrogator/TCAS Manual Tests - Continued

STEP	BUTTONS PRESSED	RESULTS/REMARKS
From "Inter Test Manual?" screen, go to Mode 1.	Press S1.	<p>In Direct Connect mode, "Mode 1 ...Direct..." screen is shown for the Mode 1 testing.</p> <p>In Radiated mode, "Mode 1XX ft." screen is shown for the Mode 1 testing.</p> <p>Tests can be repeated by pressing S2.</p> <p>The operator can go to the Interrogator Temp Setup by pressing S2 for at least 3 seconds and releasing. Refer to Table 6-6.</p> <p>The operator can view parametric data by pressing S3. Subsequent pushes of S3 displays additional parametric screens, ultimately cycling back to the first page.</p>
Continue to sequence through the individual test modes (M2, M3, MC, Mode 4A(1), Mode 4B(1), and Mode S).	Press S1 to go through each mode.	The operator can back up to a previous test in the sequence by holding down the S1 button for at least 3 seconds and releasing.
Store results (if desired).	<p>Pressing the S2 button when in the Save Test Data screen provides YES and No options.</p> <p>Press S1 to execute.</p>	Once the test sequence has been completed, the operator is given the option to save the test data to memory. If saved, the test number is displayed. In order to correlate the test results with the test aircraft the operator must record the test number and aircraft tail number. The data can be downloaded to a PC when testing has been completed.
If desired, download and view/print stored results using the bench utility (WP0008 00).	Go to WP0008 00.	

6-7.2 Interrogator Sensitivity Tests (Refer to Table 6-8.)**Table 6-8. Interrogator/TCAS Sensitivity Test**

STEP	BUTTONS PRESSED	RESULTS/REMARKS
From the "Device to test Transponder" screen, go to the "Inter Test Sensitivity?" screen.	<p>NOTE</p> <p>It may be necessary to press S2 to navigate to the appropriate interrogator test menu screen because the Test Set retains the previous state of the last test or action performed.</p> <p>Press S2, S1. Then press S2 the number of times necessary to cycle to the "Inter Test Sensitivity?" screen.</p>	"Inter Test Sensitivity?" screen is shown.
From the "Inter Test Sensitivity?" screen, go to the "MDL Test Margin" screen.	Press S1.	<p>The "MDL Test Margin" screen is shown.</p> <p>Pressing S2 will increase the Margin dB in one dB increments. The range is 0 dB to 12 dB.</p> <p>The operator can go to the Interrogator Temp Setup by pressing S2 for at least 3 seconds and releasing. Refer to Table 6-6.</p>

6-7.3 Interrogator Automatic Tests (Refer to Table 6-9.)**Table 6-9. Interrogator/TCAS Automatic Tests**

STEP	BUTTONS PRESSED	RESULTS/REMARKS
From the "Device to test Transponder" screen, go to the "Inter Test Automatic?" screen.	<p>NOTE</p> <p>It may be necessary to press S2 to navigate to the appropriate interrogator test menu screen because the Test Set retains the previous state of the last test or action performed.</p> <p>Press S2, S1. Then press S2 the number of times necessary to cycle to the "Inter Test Automatic?" screen.</p>	"Inter Test Automatic?" screen is shown.

Table 6-9. Interrogator/TCAS Automatic Tests - Continued

STEP	BUTTONS PRESSED	RESULTS/REMARKS
		The operator can go to the Interrogator Temp Setup by pressing S2 for at least 3 seconds and releasing. Refer to Table 6-6.
Store results (if desired).	Pressing the S1 button when all formats are completed at the end of the automatic testing provides the "Save Test Data?" screen. This screen provides YES and NO options. The S2 button then serves as a toggle switch between YES and NO. Press S1 to execute.	Once the test sequence has been completed, the operator is given the option to save the test data to memory. If saved, the test number is displayed. In order to correlate the test results with the test aircraft/weapons system the operator must record the test number and aircraft tail number. The data can be downloaded to a PC when testing has been completed.
If desired, download and view/print stored results using the bench utility (WP0008 00).	Go to WP0008 00.	

6-7.4 Interrogator Test Scenario (Refer to Table 6-10.)

Table 6-10. Interrogator/TCAS Test Scenario?

STEP	BUTTONS PRESSED	RESULTS/REMARKS
From the "Device to test Transponder" screen, go to the "Inter Test Scenario?" screen.	NOTE It may be necessary to press S2 to navigate to the appropriate interrogator test menu screen because the Test Set retains the previous state of the last test or action performed. Press S2, S1. Then press S2 then number of times necessary to cycle to the "Inter Test Scenario?" screen.	"Inter Test Scenario?" screen is shown. The operator can go to the Interrogator Temp Setup by pressing S2 for at least 3 seconds and releasing. Refer to Table 6-6.
For Inter Test Scenario, S1 sequences through ATRCBS level, dive, climb, above, and Mode S level, dive, climb, above.	Press S1 for the desired ATRCBS and Mode S checks.	Pressing S2 will repeat the selected test. Pressing S3 when in a test will display the scenario status (range and altitude) while in the selected test. Pressing S3 again will toggle back to the selected test screen.

6-8. GENERAL REQUIREMENTS AND SETUP FOR TCAS TESTING

The following guidelines are provided to inform the Test Set operator of typical TCAS testing setup requirements, and may be different dependent on the specific platform. Refer to platform equipment manuals for specific testing requirements.

- a. Spoof weight on wheels and / or landing gear interlocks (typically a switch in avionics bay).
- b. Spoof radar altimeter to read above 5,000 feet or disable radar altimeter IAW platform technical manual. The following steps are possible methods. (ATCRBS targets will not be correctly displayed if the radar altimeter tells the TCAS the plane is on the ground.)
 - (1) Locate radar altimeter unit and disconnect receiver antenna cable. (Typically a box with two RF connections located in avionics bay).
 - (2) Locate radar altimeter antennas and place a shield over the receive antenna. (Shield with pie pan, metal tape, etc.)
 - (3) Use a radar altimeter Test Set with appropriate antenna coupler.
- c. Spoof barometric pressure altimeter. (May not be required under some conditions.)
 - (1) If other than field altitude is needed, pump static system to 20,000 ft.
 - (2) Verify that the TCAS / Transponder system is reporting the expected altitude by testing the transponder using the TS-4530 in the Transponder Mode C test. (There are dual static ports and barometric altimeters, the TCAS / Transponder may be connected to either system.)
 - (3) Verify the TS-4530 Interrogator setup altitude is set to the aircraft altitude.
- d. Enable Mode S transponder and TCAS system via control head (Typically a small unit located in cockpit center console between seats).
 - (1) Select "TA/RA" mode on TCAS control.
 - (2) If equipped with separate Mode S and Mode 4 transponders, select Mode S transponder (instead of SIF/M4 transponder) via "Transponder 1/2" switch.
 - (3) Enable cockpit audio (To allow TCAS advisories to be heard).
- e. Adjust TCAS display unit (Typically a medium sized flat panel display located on the cockpit instrument panel).
 - (1) Set surveillance range to 20nmi. (This allows full scenario to be displayed. Shorter range selection is ok, however all TS-4530 scenarios start at 15nmi range.)
 - (2) Surveillance altitude (ABOVE, BELOW, NORMAL) should be set to match the TS-4530 target simulation. (Typically a small button on TCAS display unit labeled "A/B").
 - (a) For DIVE scenario select TCAS ABOVE display mode.
 - (b) For CLIMB scenario select TCAS BELOW display mode.
 - (c) For all other scenarios select TCAS NORMAL display mode.

- f. Start TS-4530 scenarios.
- g. Perform interrogator (manual or automatic) tests on the TCAS unit.
- h. Perform interrogator sensitivity.

6-9 PLATFORM TESTING PROBLEMS

This chart is intended to aid the operator if faults are observed during testing of an interrogator or transponder.

The Platform Testing Problem Chart (Table 6-11) is not intended to represent all common faults/causes in the system under test. It is a general starting place for fault determination and correction.

Table 6-11. Platform Testing Problem Chart

Indicated Fault	Possible Cause	Action
FAULT=ANGLE	Signal reflections	Change relative Aircraft/Weapons System/Test Set positions. Relocate aircraft away from hangar walls or other large reflective surfaces if needed.
No Replies or Low Replies	Signal reflections or Test Set aiming; inoperative IFF	Check Test Set aiming and/or change test position. Check for energized IFF; re-check using direct connect mode of testing.
ISLS Fault	IFF ISLS problem	Recheck using direct connect mode of testing. Replace IFF LRU if needed.
Incorrect distance displayed (radiated test)	Incorrect Setup	May be due to incorrect distance entered into setup. Operator must be correct distance from aircraft antenna.
Transmit Power (radiated test)	<ul style="list-style-type: none"> • Low power transmitter • Incorrect setup • Incorrect distance 	Perform direct connect mode of testing to measure actual transmitter power. Replace IFF LRU if direct connect test fails or inspect and test antenna system if direct connect mode of testing okay. May be due to incorrect distance entered into setup. Operator must be correct distance from aircraft antenna.
Receiver Sensitivity (radiated test)	<ul style="list-style-type: none"> • Poor RX sensitivity • Incorrect setup • Incorrect distance 	Perform direct connect mode of testing to measure actual receiver MTL. Replace IFF LRU if direct connect mode of testing fails or inspect and test antenna system if direct connect mode of testing ok. May be due to incorrect distance entered into setup. Operator must be correct distance from aircraft/weapons System antenna.
Pulse Timing	IFF fault	Replace IFF LRU
Transmit Frequency	IFF fault	Replace IFF LRU
Transmit Power (direct connect test)	IFF fault	Replace IFF LRU
Receiver MTL (direct connect test)	IFF fault	Replace IFF LRU

Table 6-11. Platform Testing Problem Chart - Continued

Indicated Fault	Possible Cause	Action
No intruder targets on aircraft TCAS display.	<ul style="list-style-type: none"> • Wrong altitude setup • Aircraft preparation 	May be due to incorrect altitude entered into setup. TCAS testing required aircraft to be properly prepared for testing such as correct altitude simulated with pitot/static tester and radar altimeter tester. AIR/GND switch is in proper position. Refer to specific aircraft / weapons system platform test procedures.

6-10. TEST SET SHUTDOWN

It is not necessary to turn off the Test Set. The Test Set will enter the standby mode automatically if no control buttons are pushed for 60 seconds. The unit can remain in standby for extended periods. Therefore, it is not necessary to remove the batteries during temporary storage (up to 30 days).

The Test Set will maintain the Mode 4 challenge video samples stored in the code load process after power is removed. The code loading process does not load the code of the day keys into the Test Set. A sampling of 12 mode 4 interrogations is stored for each code: A, B, Verify A, and Verify B. A Test Set which has been "Code Loaded" is not a secure device.

6-11. TEST SET OPERATING INSTRUCTIONS DECAL

The condensed operating instruction decal is located on the Test Set antenna for easy reference (see Figure 6-3).

TS-4530/UPM OPERATING INSTRUCTIONS

- **FOR MODE 4 TESTING**
 - ▶ **TRANSPONDER:** Attach KIR/KIV to unit, select M4 CODE LOAD menu, disconnect KIR/KIV.
 - ▶ **INTERROGATOR:** Attach KIT/KIV to unit. KIT/KIV must remain connected during testing.
- **ENERGIZE IFF SYSTEM TO BE TESTED.**
- **PRESS ANY BUTTON TO TURN UNIT ON.**
- **SELECT DESIRED EQUIPMENT TYPE, TEST TYPE, AND TEST DISTANCE.**
 - ▶ Press and release SEQ S1 to accept current (+) selection.
 - ▶ Press and release RPT S2 to display alternative selection(s).
 - ▶ Press and hold RPT S2 for 3 seconds to enter temporary test setup menu (if needed).
- **AIM UNIT AT SYSTEM TO BE TESTED.** Align front and rear viewfinder marks with antenna.
- **PERFORM TEST**
 - ▶ Press and release SEQ S1 to advance to the next test step.
 - ▶ Press and hold SEQ S1 for 3 seconds to step back to the previous test step.
 - ▶ Press and release RPT S2 to repeat the current test step.
 - ▶ A GREEN accept or RED reject lamp will appear at the conclusion of each test.
 - ▶ Press and release S3 to view parametric test results for the current test step.
 - ▶ When the selected test sequence is complete, the unit will return to the beginning of the sequence.
- **REPEAT ALL TESTS WHILE AIMING AT SECOND IFF SYSTEM ANTENNA (if equipped).**
- **PRESS AND HOLD S3 FOR 3 SECONDS AT ANY TIME TO SELECT DIFFERENT TESTS.**
- **UNIT WILL AUTOMATICALLY SHUT OFF (after a few minutes of inactivity).**
- **A YELLOW BATTERY INDICATES LIMITED BATTERY POWER REMAINING.**
 - ▶ Replace battery when indication flashes.

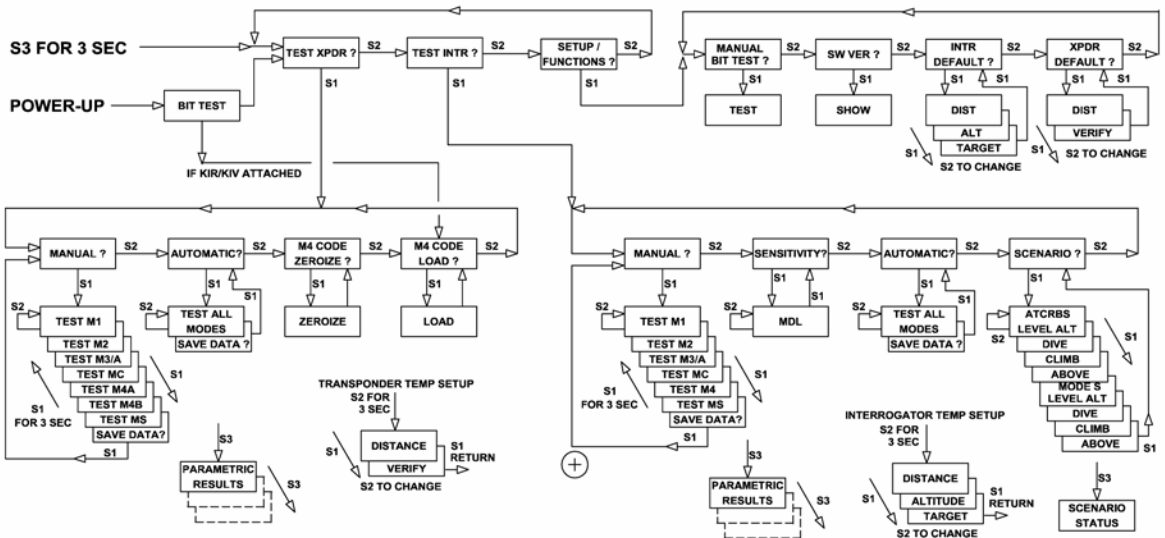

⚠ Refer to manual for detailed instructions.

Figure 6-3. Test Set Operating Instructions Decal

6-12. TEST SET BATTERY REMOVAL WARNING LABEL

Remove the batteries from the Test Set and place them in the transit case before shipment or inactive storage of 30 days or more. Shipment or storage temperatures in excess of 211°F (100°C) may cause NI-CAD batteries to release hazardous toxic materials. Figure 6-4 illustrates the battery removal warning label and its location underneath the Test Set.

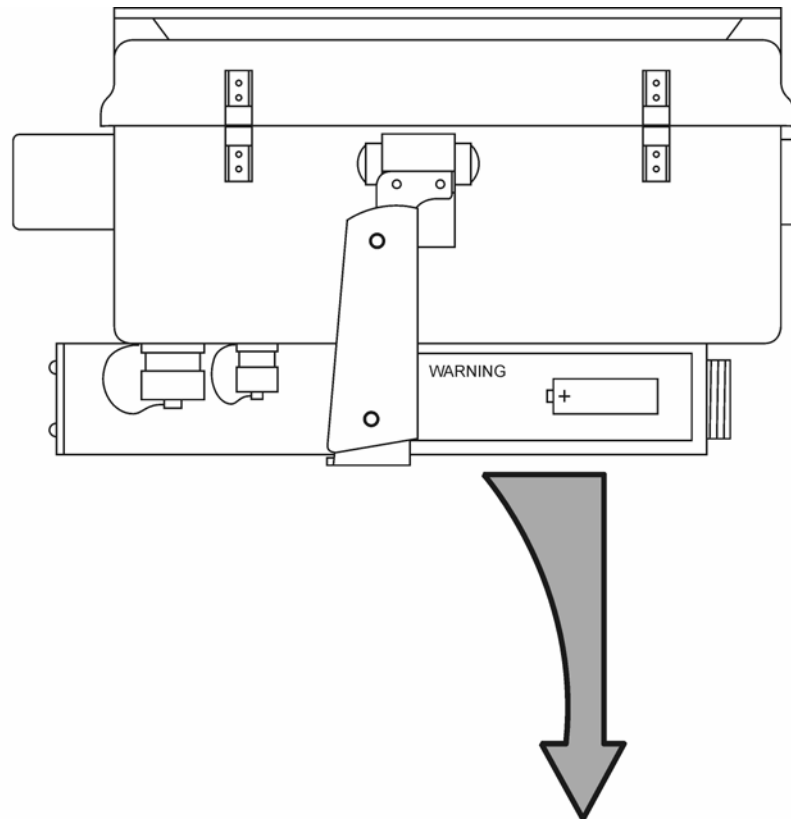

<p>WARNING Refer to manual</p> <p>For use only with the following :</p> <ul style="list-style-type: none"> ● 7.2 V rechargeable battery stick ● 6 x 1.2 V "C" cell rechargeable NiCad or NiMH batteries ● 6 x 1.5 V Alkaline "C" cell may be used only if external power is not connected <p>Remove batteries before storing unit or inactive use of more than 30 days. Use +12 to +30 Vdc external power source for operation or recharging batteries. Automatic Current Limit - To reset: remove external power and battery for 1 minute. Automatic Temperature Limit 85 °C - To reset: allow unit to cool below 40 °C</p>			<p>Insert positive (button) end first.</p>
--	--	--	--

Figure 6-4. Test Set Battery Removal Warning Label

END OF WORK PACKAGE

BATTERY CHARGING INSTRUCTIONS USING INTERNAL BATTERY CHARGER AND EXTERNAL POWER SUPPLY**WARNING**

Do not attempt to charge any batteries other than the supplied battery sticks or commercial C-size NI-CAD or NiMH batteries. This could result in battery explosion and cause injury or death.

Internal Battery Charger Operation

To charge battery:

- a. Install either battery stick or (6) commercial C-size Ni-Cad or NiMH batteries into TS-4530/UPM.
- b. Connect KIT/KIR-1C interface cable connector to the Test Set.
- c. Connect AC adapter (PN: 15-0360-M0) to KIT/KIR-1C interface cable. Connect AC adapter to 115 to 230 volt AC power.

NOTE

The Test Set can also be powered from an external DC source. Use the DC power cable and connect to a power source of 12 to 28 V dc capable of supplying at least 25 watts (2 amps at 12V or 1 amp at 28V).

- d. Battery will begin to charge automatically. When charging is complete, charger will shut off. The Test Set can be operated normally during battery charging. However, the supplied AC adapter (PN: 15-0360-M0) is for indoor use only. Approximate charge time for a fully discharged battery is 8 hours using the internal charger.

WARNING

Do not short positive and negative terminals together when handling batteries. The battery cells may EXPLODE and cause INJURY or DEATH.

WARNING

Charge only battery sticks or commercial C-size NI-CAD or NiMH batteries. Do not charge other type batteries such as alkaline, carbon, or lithium type batteries. Charging batteries other than NI-CAD or NiMH may cause them to EXPLODE and cause INJURY or DEATH.

CAUTION

The Test Set battery compartment is polarized to prevent a battery stick from making contact if installed with incorrect polarity. Do not use undue force when installing a battery stick. Damage to battery stick and/or battery charger may result.

NOTE

Battery stick will not be damaged by undercharging, but number of tests per charge will be reduced. Continuous undercharging may shorten life of battery stick.

BATTERY CHARGING INSTRUCTIONS USING EXTERNAL BATTERY CHARGER/DISCHARGER

WARNING

Do not attempt to charge any batteries other than the supplied battery sticks or commercial C-size NI-CAD or NiMH batteries. This could result in battery explosion and cause injury or death.

Operator's Controls and Indicators

Figure 7-1 shows the location of all battery charge (PN: 01-1045-10) controls, indicators, and connectors. Table 7-1 identifies and describes the function of controls, indicators, and connectors related to battery charging.

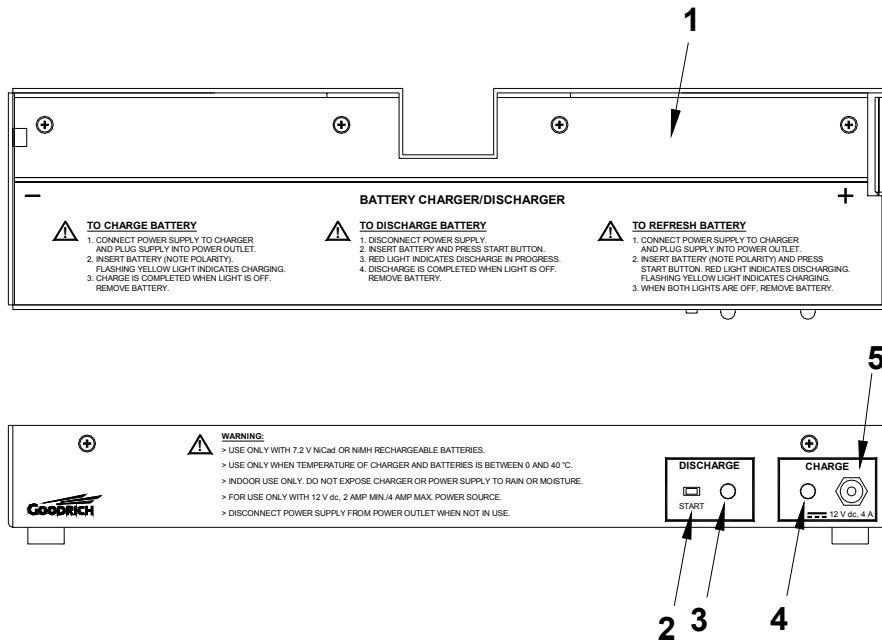

Figure 7-1. Location of Battery Charger Controls, Indicators, and Connectors

Table 7-1. Battery Charger Controls, Indicators, and Connectors

Item	Control / Indicator / Connector	Function
1	Battery Compartment	Holds battery stick or batteries while charging
2	DISCHARGE START Switch	Press to initiate battery discharge
3	Discharge LED	Red LED indicates battery stick or batteries being discharged
4	Charge LED	Flashing yellow LED indicates battery stick or batteries being charged
5	DC input	AC adapter (PN: 15-0360-M0) connects here

Battery Charging Using External Charger/Discharger

WARNING

Use only with battery sticks or commercial C-size NI-CAD or NiMH rechargeable batteries.

WARNING

Only use when temperature of charger and batteries is between 0 and 40 degrees C.

WARNING

Do not short positive and negative terminals together when handling NI-CAD or NiMH batteries. The battery cells may EXPLODE and cause INJURY or DEATH.

CAUTION

Indoor use only. Do not expose charger or AC adapter to rain or moisture.

CAUTION

Use only 12 V dc, 2 Amp minimum, 4 Amp maximum voltage regulated power source.

CAUTION

The charger battery compartment is polarized to prevent a battery stick from making contact if installed with incorrect polarity. Do not use undue force when installing a battery stick. Damage to battery stick and/or battery charger may result.

NOTE

Battery stick will not be damaged by undercharging, but number of tests per charge will be reduced. Continuous undercharging may shorten life of battery stick.

NOTE

To prevent low battery capacity memory effect, battery stick should be discharged before charging cycle is begun.

To charge battery stick or (6) commercial C-size NI-CAD or NiMH batteries, proceed as follows:

- a. Connect AC adapter (PN: 15-0360-M0) to charger and plug AC adapter into power outlet.
- b. Insert battery stick or commercial C-size NI-CAD or NiMH batteries. Flashing yellow light indicates charging.
- c. Charge is completed when light goes off. Approximate charge time for a fully discharged battery stick is 2.5 hours using the external charger.
- d. Remove battery stick or six commercial batteries and unplug AC adapter.

Battery Discharging Using External Charger/Discharger

To discharge battery stick or commercial C-size NI-CAD or NiMH batteries, proceed as follows:

- a. Unplug AC adapter (PN: 15-0360-M0).
- b. Insert battery stick or commercial C-size NI-CAD or NiMH batteries and press **DISCHARGE START** button.
- c. Red light indicates discharging process.
- d. Discharge is completed when red light goes off. Remove battery stick or six commercial batteries.

To Refresh Battery Using External Charger/Discharger

Refresh consists of a complete discharge cycle followed by a complete charge cycle. To refresh battery stick or commercial C-size NI-CAD or NiMH batteries, proceed as follows:

- a. Connect the AC Adapter (PN: 15-0360-M0) to charger and plug the AC Adapter into power outlet.
- b. Insert battery stick or (6) commercial C-size NI-CAD or NiMH batteries and press **DISCHARGE START** button.

- c. Red light will indicate discharge process, followed by flashing yellow during charging.
- d. Charging is complete when both lights are off. Remove battery stick or six commercial batteries and unplug AC adapter.

END OF WORK PACKAGE

INTRODUCTION

The TS-4530/UPM Bench Utility (PN: 60-0694-B5) is designed to allow remote access to the TS-4530/UPM. This program can be used to download and view test data records stored in the unit.

INSTALLATION

Minimum System Requirements:

- IBM PC compatible
- Comm 1 Serial port capable of 9,600 baud rate
- 90 MHz Intel Pentium processor (or better) with one of the following:
 - Microsoft Windows 95/98
 - NT4.x with Service Pack 3 or above
 - NT2000
- CD-ROM drive
- 10 Meg hard drive space
- 16 Meg RAM (32 Meg recommended)
- Mouse
- 800 x 600 VGA graphics (or better)

NOTE

Any serial port (Comm 1 – 4) may be used with this Software. The program will search Comm ports 1 through 4, to find the unit.

NOTE

Prior to installing this software on a computer, all previous versions of this software must be uninstalled from the target computer first.

To uninstall a previous version of this software, click on the Start Menu and select "Settings", "Control Panel", then "Add/Remove Programs". In the program list box that appears, locate and select TS-4530/UPM Bench Utility, then click the "Add/Remove" Button.

Insert the supplied CD-ROM for the TS-4530/UPM Bench Utility into the CD-ROM drive. On most computers, the installation process will begin automatically. On some computers, the installation will not begin automatically and the program installation must be started manually.

To manually start the installation process, click on the Start Menu and select "Run". In the dialog box that appears, type the following:

D:\setup

where D is the drive letter of the CD-ROM drive on the computer. After typing the above, click "OK".

OPERATION

To start the Bench Utility, click “Start” on the Desktop Taskbar and go to “Programs”, “TS-4530/UPM”, then select “Bench Utility”. The Test Manager screen will appear as shown in Figure 8-1.

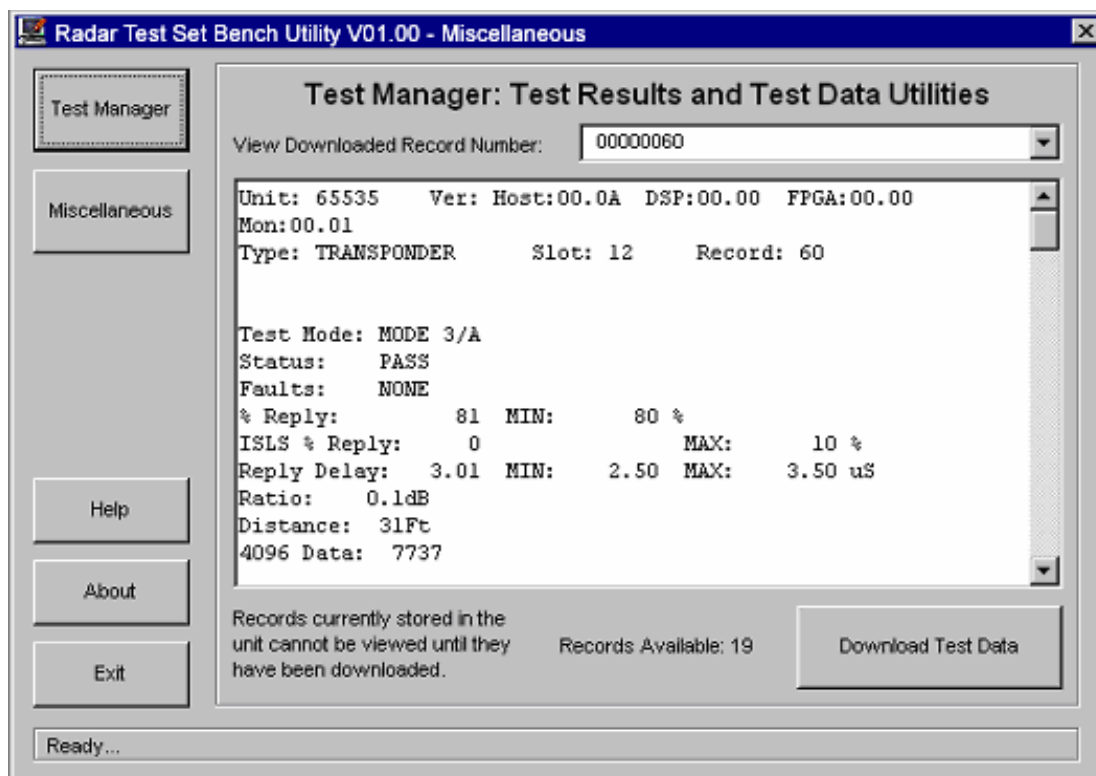

Figure 8-1. Test Manager Panel

NOTE

The program automatically searches for a Test Set when it starts. A Test Set can be connected at any time. A message will pop-up to indicate if a Test Set is not detected. The operator can connect a Test Set and press “Retry” or press “Cancel” to connect a Test Set later.

The program interface consists of two parts. The menu bar consists of the column of buttons on the left of the program window. Use these buttons to select the desired program activity. The available selections are “Test Manager”, and “Miscellaneous”. The user can toggle between the two panels by selecting the appropriate button. In addition, “Help”, “About”, and “Exit” buttons are located on the menu bar.

1. Test Manager

The “Test Manager” button displays a panel that can be used to download and view test data records stored in the TS-4530/UPM. Prior to viewing test data records, they must first be downloaded from the unit to the computer.

To download the test data from the TS-4530/UPM, first ensure that the unit has power and is attached to the serial port (Comm 1 - 4) of the computer with the provided 9 pin RS-232 serial cable (PN: 55-1045-15).

The "Records Available" indicator shows the number of test data records available for download from the unit. Use the "Download Test Data" button to retrieve the test data from the unit. Once this is complete, use the drop down menu entitled "View Downloaded Record Number" to browse the records downloaded from the unit.

Note that once a test data record is downloaded from the unit, it is not necessary to download it from the unit in the future as it is no longer stored on the unit; it is permanently stored on the computer to which it was downloaded. Previously downloaded test data records can be viewed using the drop down menu entitled "View Downloaded Record Number". The file name in the drop down menu has the unit serial number followed by the record number.

2. Miscellaneous

When the "Miscellaneous" button is pushed, the panel will appear as shown in Figure 8-2.

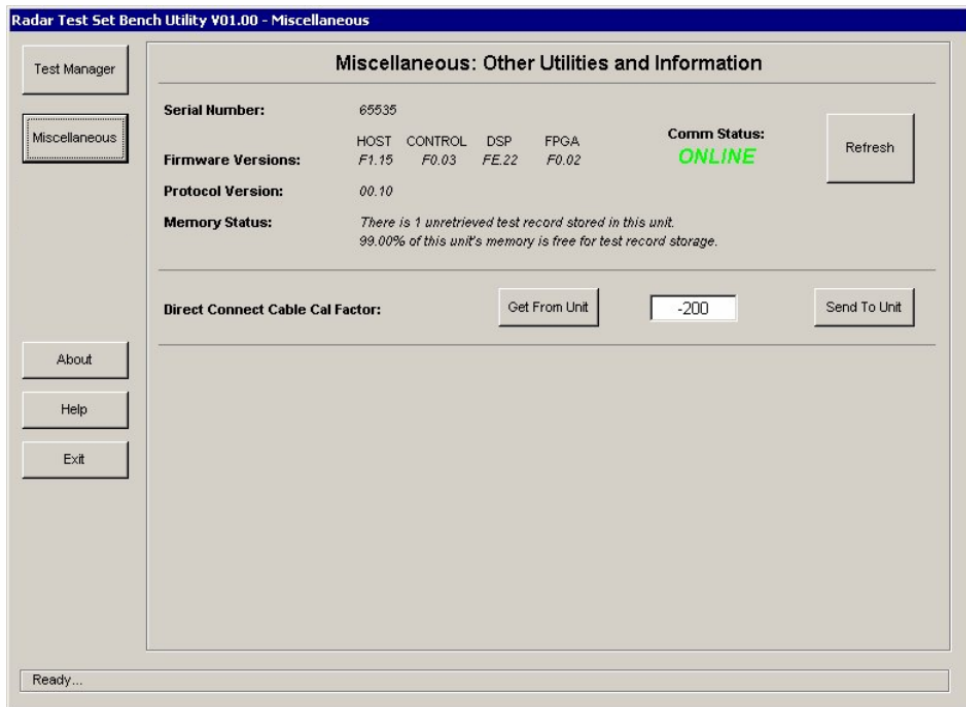

Figure 8-2. Miscellaneous Panel

The "Miscellaneous" button displays a panel that provides general information about the program and the TS-4530/UPM currently attached to the computer (if there is one). The serial number, firmware version numbers, protocol version and memory status of the unit are all provided here.

Use the "Refresh" button to connect the TS-4530/UPM when experiencing communication difficulties between the computer and the unit. This button can also be used for reconnecting to a unit after operating the program without a unit connected.

Direct Connect Cable Cal Factor

This allows the user to utilize a different cable if desired. The average loss of the cable at 1030 and 1090 MHz is entered into the Test Set using "Send to Unit". "Get From Unit" allows the user to view the current value stored in the Test Set. The cal factor is printed on the direct connect cable provided with the Test Set.

About communication with the TS-4530/UPM:

Serial communication between the TS-4530/UPM and the computer is intended to occur in the background, transparent to the user. However, during communication difficulty, the program may provide notification to the user of the difficulty experienced. If a unit has no power, is not connected to the computer, or the connection to the computer has been interrupted, error notification is normal. This is done to allow the user the opportunity to either attempt communication again (when attempting to resolve a communication problem) or cancel communication attempts (when browsing previously downloaded test data records while a unit is not attached).

3. Help Button

When the "Help" button is pushed, a panel will appear with contact information from the manufacturer for assistance.

4. About Button

When the "About" button is pushed, information about the software license will appear.

5. Exit Button

When the "Exit" button is pushed, the program will terminate.

END OF WORK PACKAGE

EMERGENCY COMMERCIAL C-SIZE BATTERY INSTALLATION

If a battery stick is not available, six commercial C-size batteries may be used in its place as shown in Table 9-1:

Table 9-1. Battery Compatibility Chart

Battery Type	Min Temp	Recharge	Recommendation
Stick (NI-CAD)	-40 C	Yes	Recommended
NI-CAD C cells	-20 C	Yes	Acceptable
NiMH C cells	-20 C	Yes	Acceptable
Alkaline C cells	-20 C	No	Emergency Use

The supplied battery stick uses 3000 mA hour high capacity rapid charge NI-CAD batteries that have superior cold temperature performance and are memory effect resistant.

NI-CAD and NiMH batteries common to local retail stores are usually standard capacity and temperature range batteries that will provide less operating time than the supplied battery stick. It is preferable to utilize premium performance batteries when available. Use batteries that are suitable for fast charging. Do not use batteries that specify a minimum recharge time that is greater than 2 hours.

Alkaline batteries will provide satisfactory operation of the Test Set, with the exception that the low battery indication may not provide acceptable warning of impending battery exhaustion. The use of alkaline batteries should be limited to those applications where power for recharging is not available, or for emergency use when a charged battery is not available.

Standard Carbon-Zinc batteries should never be used as they cannot supply the peak power needed during some of the tests.

Install six commercial, C-size batteries as shown below in Figure 9-1.

- a. Remove end cap. Remove discharged battery stick from Test Set, if installed.

NOTE

Test Set will not be damaged if the batteries are inserted so that polarity is incorrect. Test Set will not operate until batteries are correctly installed.

- b. Insert six commercial C-size batteries, making sure that positive terminal of each battery is inserted first (toward Test Set eyepiece). Install end cap and tighten snugly.
- c. Observe POWER-ON BIT TEST.

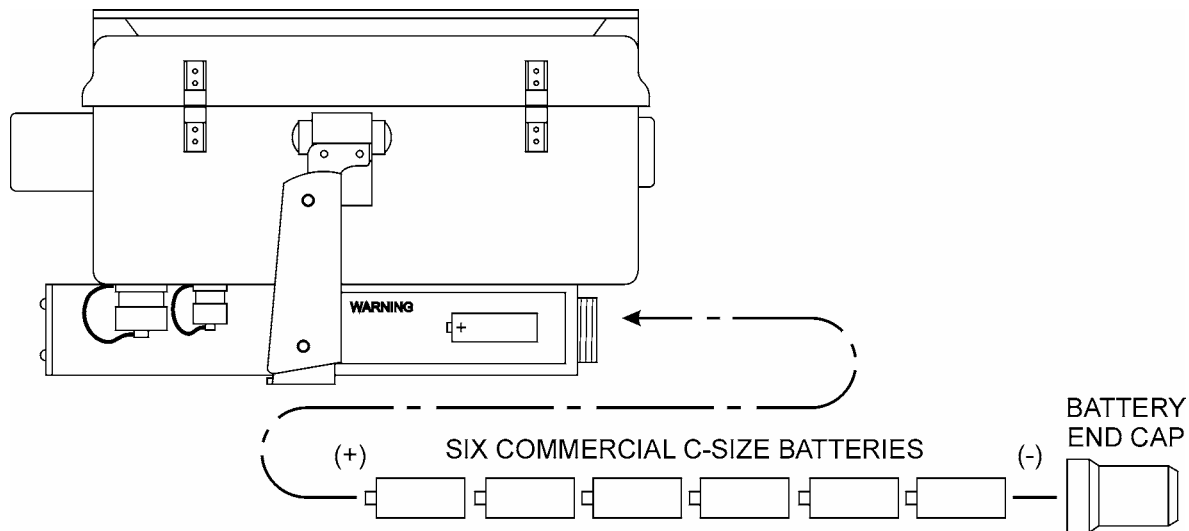

Figure 9-1. Test Set Commercial C-size Battery Installation

BATTERY OPERATION BELOW 0 DEGREES C

Battery endurance and lifetime is degraded at cold temperatures. For best performance, store spare batteries in a room temperature location and expose to cold temperatures only when necessary.

Never attempt to recharge a cold battery. Always allow the battery to warm to room temperature before recharging.

NOTE

The temperature sensing circuits of the charger at room temperature will not correctly sense the temperature of a cold battery that has just been inserted.

The Test Set internal battery charger is disabled when the Test Set is below approximately 0° C or above approximately 40°C. Therefore, supplying external DC to a cold Test Set with a battery installed is acceptable. The internal charger will automatically start operation when the Test Set has warmed to acceptable temperatures.

END OF WORK PACKAGE

TM 43-6625-916-12

CHAPTER 3

TROUBLESHOOTING PROCEDURES

CHAPTER 3 INDEX

WP Sequence No.

MALFUNCTION/SYMPTOM INDEX.....	0010 00
Malfunction/Symptom Index	0010 00-1
Troubleshooting Procedures	0010 00-1
Malfunction/Symptom Index (Table 10-1).....	0010 00-1
TROUBLESHOOTING SECTION TS001, POWER PROBLEMS	0011 00
TROUBLESHOOTING SECTION TS002, POWER PROBLEMS	0012 00
TROUBLESHOOTING SECTION TS003, INTERFACE PROBLEMS.....	0013 00
TROUBLESHOOTING SECTION TS004, SELF CHECK PROBLEMS	0014 00
TROUBLESHOOTING SECTION TS005, SELF CHECK PROBLEMS	0015 00
TROUBLESHOOTING SECTION TS006, OPERATIONAL PROBLEM.....	0016 00
TROUBLESHOOTING SECTION TS007, SELF CHECK PROBLEMS	0017 00
TROUBLESHOOTING SECTION TS008, OPERATIONAL PROBLEM.....	0018 00
TROUBLESHOOTING SECTION TS009, OPERATIONAL PROBLEM.....	0019 00
TROUBLESHOOTING SECTION TS010, OPERATIONAL PROBLEM.....	0020 00
TROUBLESHOOTING SECTION TS011, OPERATIONAL PROBLEM.....	0021 00
TROUBLESHOOTING SECTION TS012, UTILITY SOFTWARE PROBLEM	0022 00

MALFUNCTION/SYMPTOM INDEX

The malfunction/symptom index (Table 10-1) is a quick reference index for finding troubleshooting procedures.

TROUBLESHOOTING PROCEDURES

The troubleshooting work packages list the symptoms, malfunctions, and corrective actions required to return the Test Set to normal operation. Perform the steps in the order they appear. Before performing any troubleshooting, perform a detailed visual inspection to check for obvious physical damage or abuse that could contribute to the problem.

If a malfunction is not listed or is not corrected by listed corrective actions, notify the next higher level maintenance.

Table 10-1. Malfunction/Symptom Index

Category	Malfunction/Symptom	Troubleshooting Section	Work Package
<i>Self check Problems</i>			
	Test Set is "dead", blank display, no internal lights	TS004	WP0014 00
	Power up BIT test and/or self-calibration fails.	TS007	WP0017 00
	BIT test and/or self-calibration failures during operation.	TS007	WP0017 00
	Display check fails	TS005	WP0015 00
<i>Operational Problems</i>			
	Test Set does not operate.	TS004	WP0014 00
	Test Set goes dark and appears "dead".	TS004	WP0014 00
	Push button switches are intermittent or do not work	TS008	WP0018 00
	Test Set does not work in radiated mode but works okay in direct connect.	TS009	WP0019 00
	Test Set does not work in direct connect mode but works okay in radiated mode.	TS010	WP0020 00
	Consistent "Fault=No Replies" messages or low percent reply.	TS011	WP0021 00
	Consistent power, frequency, or reply delay errors.	TS011	WP0021 00
	Consistent "Fault=Angle" messages.	TS011	WP0021 00
	Small yellow and/or red lights visible inside Test Set not on the display. Sometimes, yellow light blinks.	TS006	WP0016 00
	Blinking yellow light not visible when battery is being charged from external power.	TS006, TS001	WP 0016 00 WP0011 00
<i>Interface Problems</i>			
	Cannot load Mode 4 Codes.	TS003	WP0013 00
	Cannot detect KIT/KIV for interrogator testing.	TS003	WP0013 00
	Cannot load Mode 4 Codes for transponder testing.	TS003	WP0013 00
<i>Power Problems</i>			
	Test Set does not charge internal battery.	TS001	WP0011 00
	Test Set does not work on battery power but works okay on external power.	TS001	WP0011 00

Category	Malfunction/Symptom	Troubleshooting Section	Work Package
	Test Set does not work from external power but works okay from battery.	TS002	WP0012 00
	Test Set does not work from AC Adapter (PN: 15-0360-M0) but works okay from other external power.	TS002	WP0012 00
	Test Set does not work from external power but works okay from AC Adapter (PN: 15-0360-M0).	TS002	WP0012 00
	Yellow light visible inside Test Set when battery is not being charged from external power.	TS006	WP0016 00
Utility Software Problems			
	Cannot communicate with external computer using the Bench Utility Software.	TS012	WP0022 00

END OF WORK PACKAGE

SYMPTOM

Test Set does not charge internal battery.

MALFUNCTION

Defective battery.

CORRECTIVE ACTION

Replace the battery stick (WP0005 00).

MALFUNCTION

Defective AC Adapter (PN: 15-0360-M0).

CORRECTIVE ACTION

Replace AC Adapter

MALFUNCTION

Defective Power Supply Board (PNP 20-6870-30).

CORRECTIVE ACTION

Refer to the next higher level of maintenance.

SYMPTOM

Test Set does not work on battery power but works okay on external power.

MALFUNCTION

Battery cap not tight.

CORRECTIVE ACTION

Tighten battery cap and clean the negative contact.

MALFUNCTION

Battery is too hot (above 40°C) or too cold (below 0°C).

CORRECTIVE ACTION

Allow the Test Set and/or battery to reach a temperature between 32°F and 104°F (0°C and 40°C). The battery protection circuit is preventing charging.

SYMPTOM

Blinking yellow light not visible when battery is being charged from external power.

MALFUNCTION

External power problem.

CORRECTIVE ACTION

Perform external charging troubleshooting TS002 (WP0012 00).

MALFUNCTION

Defective Power Supply Board (PN: 20-6870-30).

CORRECTIVE ACTION

Refer to the next higher level of maintenance.

END OF WORK PACKAGE

SYMPTOM

Test Set does not work from external power but works okay from battery.

MALFUNCTION

1. Resettable electronic fuse on Power Supply Board tripped.
2. Defective AC Adapter (PN: 15-0360-M0).
3. Defective external source.
4. Defective KIT/KIR-1C Interface Cable Assembly (PN: 55-1045-10).
5. Defective Power Supply Board (PN: 55-1045-14)
6. Defective A7 Main Connector Assembly (PN: 20-6870-30).

CORRECTIVE ACTION

1. Remove external power and battery. Allow Test Set to cool to room temperature. Fuse will automatically reset. Reapply power.
2. Replace the External AC Adapter (PN: 15-0360-M0).
3. Replace external DC power source.
4. Replace KIT/KIR-1C Interface Cable Assembly (PN: 55-1045-10).
5. Replace Power Supply Board (PN: 55-1045-14).
6. Replace A7 Main Connector Assembly (PN: 20-6870-30).

SYMPTOM

Test Set does not work from AC Adapter (PN: 15-0360-M0), but works okay from other external power.

MALFUNCTION

Defective AC Adapter (PN: 15-0360-M0).

CORRECTIVE ACTION

Replace the AC Adapter (PN: 15-0360-M0).

SYMPTOM

Test Set does not work from external power but works okay from AC Adapter (PN: 15-0360-M0).

MALFUNCTION

Defective external power supply source.

CORRECTIVE ACTION

Use another external power supply source.

MALFUNCTION

Reverse polarity from external power supply.

CORRECTIVE ACTION

Reverse power leads of External DC POWER CABLE (PN: 55-1045-14) connected to the external power supply.

MALFUNCTION

Defective External DC Power Cable (PN: 55-1045-14).

CORRECTIVE ACTION

Replace defective External DC Power Cable (PN: 55-1045-14).

END OF WORK PACKAGE

SYMPTOM

- Cannot load Mode 4 codes.
- Cannot detect KIT for interrogator testing.
- Cannot load Mode 4 codes for transponder testing.
- Cannot retain Mode 4 codes.

MALFUNCTION

External COMSEC device does not have a valid key code loaded into it or may be defective.

CORRECTIVE ACTION**NOTE**

The Test Set detects an external COMSEC device. A failure to detect may be indicated by "NO COMSEC KEY" or "NOT AVAILABLE" message on the display. The KIT/KIR-1C electrical signals are generated and received on the DSP board then routed through the power supply Board, main connector assembly, and the KIT/KIR-1C interface cable.

Verify external COMSEC device has a valid key code loaded into it and load code per procedure in WP0005 00 (Mode 4 Zeroize Procedure).

MALFUNCTION

COMSEC battery is not operating properly.

NOTE

The COMSEC battery must be working. Otherwise correctly loaded Mode 4 codes will be erased when the COMSEC powers down or is disconnected.

CORRECTIVE ACTION

Replace the battery in the KIT-1C or KIR-1C COMSEC device.

MALFUNCTION

Defective KIT/KIR-1C interface cable assembly (PN: 55-1045-10).

CORRECTIVE ACTION

Replace KIT/KIR-1C interface cable assembly (PN: 55-1045-10).

MALFUNCTION

Defective PCBs and/or main connector assembly.

CORRECTIVE ACTION

Refer to the next higher level of maintenance.

END OF WORK PACKAGE

SYMPTOM

- Test Set goes dark and appears “dead”.
- Test Set is “dead” with blank display and no internal lights.
- Test Set does not operate.

MALFUNCTION

Test Set is in standby power down mode.

NOTE

To conserve battery life, the Test Set automatically powers down if the buttons are not pushed.

CORRECTIVE ACTION

Push any button to return Test Set to previous power-on condition.

MALFUNCTION

Battery is dead.

CORRECTIVE ACTION

Replace the battery stick (WP0005 00, BATTERY STICK INSTALLATION) or operate from external power.

MALFUNCTION

Power up BIT test and/or calibration detected errors.

CORRECTIVE ACTION

Refer to next higher level of maintenance for performing the BIT test and the self-calibration Troubleshooting Section TS007 (WP0017 00).

MALFUNCTION

The display board is defective.

CORRECTIVE ACTION

Refer to the next higher level of maintenance.

END OF WORK PACKAGE

SYMPTOM

Display Check fails.

MALFUNCTION

Test Set could be completely dead.

CORRECTIVE ACTION

Perform the "dead" Test Set troubleshooting section TS004 (WP0014 00).

MALFUNCTION

Display Board and/or DSP Board is defective.

CORRECTIVE ACTION

Refer to the next higher level of maintenance.

END OF WORK PACKAGE

SYMPTOM

Small yellow and/or red light visible inside Test Set not on the display. Sometimes the yellow light blinks.

MALFUNCTION

Normal operation.

CORRECTIVE ACTION

The DSP Board and Power Supply board contain LEDs. The yellow light on the Power Supply blinks when the battery is being charged from external power.

SYMPTOM

Yellow light is visible inside Test Set when the battery is not being charged from external power.

MALFUNCTION

Defective Power Supply Board (PN: 20-6870-30).

CORRECTIVE ACTION

Refer to the next higher level of maintenance.

SYMPTOM

Blinking yellow light is not visible inside Test Set when the battery is being charged from external power.

MALFUNCTION

Defective battery charging from external supply.

CORRECTIVE ACTION

Perform the battery charging troubleshooting Section TS001 (WP0011 00).

END OF WORK PACKAGE

SYMPTOM

BIT test or self-calibration failure.

MALFUNCTION

Defective DSP Board (PN: 20-6870-00).

CORRECTIVE ACTION

Refer to the next higher level of maintenance.

MALFUNCTION

Defective DSP Board (PN: 20-6870-00).

CORRECTIVE ACTION

Refer to the next higher level of maintenance.

END OF WORK PACKAGE

SYMPTOM

Push button switches are intermittent or do not work.

MALFUNCTION

Defective switch.

CORRECTIVE ACTION

Replace Switch Assembly (PN: 20-1045-A0). Refer to next higher level of maintenance.

MALFUNCTION

Defective DSP Board (PN: 20-6870-00).

CORRECTIVE ACTION

Refer to the next higher level of maintenance.

END OF WORK PACKAGE

SYMPTOM

Test Set does not work in radiated mode but works okay in direct connect.

MALFUNCTION

Defective Antenna Assembly (PN: 20-6870-00).

CORRECTIVE ACTION

Refer to next higher level of maintenance.

MALFUNCTION

Defective RF Board (PN: 20-6870-30).

CORRECTIVE ACTION

Refer to next higher level of maintenance.

MALFUNCTION

Defective DSP Board (PN: 20-6870-00).

CORRECTIVE ACTION

Refer to next higher level of maintenance.

END OF WORK PACKAGE

SYMPTOM

Test Set does not work in direct connect mode but works okay in radiated mode.

MALFUNCTION

Defective External Direct Connect Cable Assembly (PN: 55-1045-11).

CORRECTIVE ACTION

Replace External Direct Connect Cable Assembly (PN: 55-1045-11).

MALFUNCTION

Defective Attenuator Assembly (PN: 20-6870-A1).

CORRECTIVE ACTION

Refer to the next higher level of maintenance.

MALFUNCTION

Defective RF Board (PN: 60-6870-30).

CORRECTIVE ACTION

Refer to the next higher level of maintenance.

END OF WORK PACKAGE

SYMPTOM

- Consistent “Fault=No Replies” messages or low percent reply.
- Consistent power, frequency, or reply delay errors.
- Consistent “Fault=Angle” messages.

MALFUNCTION

Displayed messages of “Fault=No Replies” and “Fault=Angle” can be caused by improper operation of the Test Set.

CORRECTIVE ACTION

Operator should change position to reduce reflections from large surfaces such as rotor blades, hangar walls/doors, vehicles, and work carts.

MALFUNCTION

Defective RF Board (PN: 60-6870-30).

CORRECTIVE ACTION

Refer to the next higher level of maintenance.

MALFUNCTION

Defective DSP Board (PN: 20-6870-00).

CORRECTIVE ACTION

Refer to the next higher level of maintenance.

MALFUNCTION

Defective Antenna Assembly (PN: 20-6870-A3).

CORRECTIVE ACTION

Refer to the next higher level of maintenance.

END OF WORK PACKAGE

SYMPTOM

Cannot communicate with external computer using the Bench Utility Software.

MALFUNCTION**NOTE**

The TS-4530/UPM Test Set communicates via RS-232 serial communication to the external computer.

Incorrect computer configuration.

CORRECTIVE ACTION

1. Ensure that the RS-232 cable is connected to any Comm Port on the computer.
2. Reinstall the Bench Utility Software following the instructions in WP0008 00.

MALFUNCTION

Defective RS-232 9-pin computer cable (PN: 55-1045-15).

CORRECTIVE ACTION

Replace RS-232 9-pin computer cable (PN: 55-1045-15).

MALFUNCTION

Defective KIT/KIR-1C Interface Cable Assembly (PN: 55-1045-10).

CORRECTIVE ACTION

Replace KIT/KIR-1C Interface Cable (PN: 55-1065-10).

MALFUNCTION

Defective PC.

CORRECTIVE ACTION

Connect to a known operational PC and retry.

MALFUNCTION

Defective DSP Board (PN: 20-6870-00).

CORRECTIVE ACTION

Refer to the next higher level of maintenance.

MALFUNCTION

Defective Power Supply Board (PN: 20-6870-30).

CORRECTIVE ACTION

Refer to the next higher level of maintenance.

MALFUNCTION

Defective Main Connector Assembly (PN: 20-6870-00).

CORRECTIVE ACTION

Refer to the next higher level of maintenance.

END OF WORK PACKAGE

TM 43-6625-916-12

CHAPTER 4

MAINTENANCE INSTRUCTIONS

CHAPTER 4 INDEX

WP Sequence No.

SERVICE UPON RECEIPT	0023 00
Unpacking	0023 00-1
Inspection	0023 00-1
PREVENTIVE MAINTENANCE CHECKS AND SERVICES (PMCS)	0024 00
General	0024 00-1
Preventive Maintenance Checks and Services	0024 00-1
Preventive Maintenance Checks and Services (Table 24-1)	0024 00-1
GENERAL MAINTENANCE INSTRUCTIONS	0025 00
Tools and Materials	0025 00-1
Cleaning	0025 00-1
Lubrication	0025 00-1
Replacement of Test Set Operating Instructions Decal	0025 00-1
Minor Repair of Cables	0025 00-1
PREPARATION FOR STORAGE, MOVEMENT, AND SHIPMENT	0026 00
Preparation for Movement	0026 00-1
Preparation for Inactive Storage or Shipment	0026 00-1

UNPACKING

The Radar Test Set, TS-4530/UPM is shipped assembled in its original packing container. Unpack carefully and do not damage the container. If possible, save the container for use in reshipment when requesting warranty work. When keeping and storing the original packaging is not possible, see paragraph i, WP 0026 00.

INSPECTION

Inspect the equipment for damage incurred during shipment. If the equipment has been damaged, report the damage on SF Form 361, Transportation Discrepancy Report. If a claim for damage is to be, save the shipping container to substantiate the claim. Remove any protective covers from containers before using the equipment. Replace any covers on the connectors after using the TS-4530/UPM Test Set.

Check the equipment against the packing slip to see if the shipment is complete. Report all discrepancies in accordance with instructions of DA Pam 738-750.

Check to see whether the equipment has been modified. Refer to DA PAM 25-30.

END OF WORK PACKAGE

GENERAL

Operator's preventive maintenance checks and services (PMCS) are designed to help maintain equipment in serviceable condition. They include items to be checked and how to check them. These checks and services are to be made at specific intervals before (B), weekly (W), quarterly (Q), and periodic intervals.

Routine checks like CLEANING, PRESERVATION, DUSTING, WASHING, CHECKING FOR FRAYED CABLES, STOWING ITEMS NOT IN USE, COVERING UNUSED RECEPTACLES, CHECKING FOR LOOSE NUTS AND BOLTS AND COMPLETENESS are not listed as PMCS checks. They are things that you should do any time you see they must be done. If you find a routine check like one of those listed in your PMCS, it is because other operators reported problems with this item.

NOTE

When you are doing any PMCS or routine checks, keep in mind the WARNINGS and CAUTIONS. The PROCEDURES column in your PMCS chart instruct how to perform the required checks and services. Carefully follow these instructions.

PREVENTIVE MAINTENANCE CHECKS AND SERVICES

Table 24-1 lists the preventive maintenance checks and services for the Test Set. These checks and services are classified as BEFORE OPERATION, WEEKLY, AND QUARTERLY. Correct deficiencies as instructed. Refer to maintenance instructions and work packages as required. Deficiencies that cannot be corrected must be reported to the next higher level of maintenance.

Table 24-1. Preventive Maintenance Checks and Services

B – Before W – Weekly Q – Quarterly

Item No.	Interval			Item to be Inspected	Procedure
	B	W	Q		
1		*		Battery Stick	Inspect for dents, deep scratches, and leakage. Replace at first sign of leakage. NOTE Battery stick(s) must be charged before operation of Test Set.
2	*			Battery Stick/ External Battery Charger/AC Adaptor	Charge battery sticks for approximately 6 hrs. (in Test Set) or approximately 2 hrs. (in external charger). Refer to WP0007 00.
3	*			Eyepiece Lens	Inspect for cracks, scratches, or breaks. Refer to next higher level of maintenance for replacement.
4	*			Operation	Perform a BIT test in accordance with WP0005 00, PERFORM BIT TEST AND DISPLAY CHECK.
5		*		Sighting Window	Inspect for cracks, scratches, or breaks. Higher level of maintenance required.
6			*	Battery Stick/External Battery Charger/AC Adaptor	Refresh the battery sticks (fully discharge then recharge). May take up to 4 hours to discharge depending on the battery charge state followed by a 2 hour automatic recharge.

END OF WORK PACKAGE

TOOLS AND MATERIALS

No tools or equipment are required for general maintenance. Materials required are listed in Work Package 0030 00.

CLEANING**WARNING**

Make sure all power sources are removed from the Test Set to prevent shock.

Clean all surfaces and control knobs with a soft, clean cloth. If dirt is difficult to remove, dampen the cloth with water and use a mild soap. Do not use soapy water to clean connectors. Clean exterior metal surfaces as follows:

- a. Remove moisture and loose dirt with a clean, soft cloth.
- b. Remove grease, fungus, and ground-in-dirt from exterior; use a cloth dampened (not wet) with isopropyl alcohol.
- c. Remove dirt from hard to reach areas with a brush.

CAUTION

Do not use soapy water to clean connectors.

- d. Check all cables and connectors for dirt or foreign matter.

LUBRICATION

No lubrication is required for the Test Set.

REPLACEMENT OF TEST SET OPERATING INSTRUCTIONS DECAL

Remove and replace the decal as follows:

- a. Remove damaged or loose decal (WP0006 00, Figure 6-3) by gently peeling decal off antenna.
- b. Using a clean, soft cloth moistened with isopropyl alcohol, wipe antenna until clean.
- c. Position new decal (PN: 57-5054-B0) over antenna so that holes in decal line up with antenna screw heads. Install decal.
- d. Using a clean, soft cloth, work air bubbles out by pressing from decal center outward. Repeat until all air bubbles are worked out.

MINOR REPAIR OF CABLES

Repair minor cuts in cable insulation by covering it first with insulation tape, and then with plastic tape. Replace broken or damaged cables.

END OF WORK PACKAGE

PREPARATION FOR MOVEMENT

Prepare radar Test Set for movement as follows:

- a. If connected, disconnect KIT/KIR-1C interface cable (PN: 55-1045-10) from Test Set.
- b. Remove battery end cap and remove battery stick from Test Set.

WARNING

Do not short positive and negative terminals together when handling NI-CAD batteries. If you short the battery terminals, the battery cells may EXPLODE and cause you INJURY or DEATH.

- c. Store battery stick(s) and CDs in the slots provided in the transit case.
- d. Store AC Adaptor, Battery Charger/Discharger, KIT/KIR Interface Cable, RS-232 Cable, AC Power Cord, and Direct Connect Cable in the slots provided in the transit case.
- e. Store Test Set in transit case.
- f. Check TS-4530/UPM for completeness (WP0029 00).
- g. Close the transit case lid and tighten the five case latches.

PREPARATION FOR INACTIVE STORAGE OR SHIPMENT

Prepare radar Test Set for inactive storage or shipment as follows:

- a. If connected, disconnect KIT/KIR interface cable from Test Set.
- b. Remove battery end cap and remove battery stick from Test Set.
- c. If required for shipment, discharge battery stick in accordance with battery stick discharging procedure (WP0007 00). It is recommended that the battery stick and commercial NiCAD batteries be stored in a discharged state to maximize battery life.

WARNING

Do not short positive and negative terminals together when handling NI-CAD batteries. If you short the battery terminals, the battery cells may EXPLODE and cause you INJURY or DEATH.

WARNING

Test Set batteries must be removed from Test Set and placed in transit case before shipment or inactive storage of 30 days or more. Extremely high shipment or storage temperatures (greater than 100 degrees C) may cause NI-CAD batteries in the battery stick to release toxic materials which are hazardous to you.

NOTE

When discharging battery stick, it is necessary to disconnect the battery charger from primary power.

- d. Store battery stick(s) and External Battery Charger/Discharger in the slots provided in the transit case.
- e. Store KIT/KIR-1C Interface Cable, RS-232 Cable, AC Power Cord, AC Adapter, and Direct Connect Cable in central compartment of transit case.
- f. Store Test Set in transit case.
- g. Check radar Test Set for completeness (WP0029 00).
- h. Close the transit case lid and tighten the five case latches.
- i. If original packing material was saved, pack the radar Test Set in the same manner as it was received. When using packing materials other than the original, repackage the instrument with commercially available materials, as follows:
 - (1) Use a strong shipping container. The carton must be both large enough and strong enough to accommodate the TS-4530/UPM. Select a double-walled, corrugated cardboard carton with 159 kg (350 lb). Allow at least 3 to 4 inches on all sides of the Test Set for packing material.
 - (2) Surround the equipment with three to four inches of packing material and prevent the equipment from moving in the carton. If packing foam is not available, the best alternative is a plastic sheet filled with 1-1/4 inch air bubbles. Wrapping the equipment several times in this material should both protect the equipment and prevent it from moving in the carton.
 - (3) Seal the shipping container securely with strong nylon adhesive tape.
 - (4) Mark the shipping container "FRAGILE, HANDLE WITH CARE" to assure careful handling.
 - (5) Retain copies of all shipping papers.

END OF WORK PACKAGE

TM 43-6625-916-12

CHAPTER 5

SUPPORTING INFORMATION

CHAPTER 5 INDEX

WP Sequence No.

REFERENCES.....	0027 00
MAINTENANCE ALLOCATION CHART.....	0028 00
COMPONENTS OF END ITEM (COEI) AND BASIC ISSUE ITEMS (BII) LIST	0029 00
EXPENDABLE AND DURABLE ITEMS LIST.....	0030 00

SCOPE

This work package lists all forms, field manuals, technical manuals, and miscellaneous publications referenced in this manual.

FORMS

Product Quality Deficiency Report	SF 368
Recommended Changes to Publications and Blank Forms	DA Form 2028
Report of Discrepancy (ROD)	SF 364
Transportation Discrepancy Report (TDR)	SF 361

TECHNICAL MANUALS

TEMOD IETM EM 0236 for Radar Test Set, TS-4530/UPM	TM 43-6625-001-14&P
Procedures for Destruction of Electronic Material to Prevent Enemy Use (Electronics Command)	TM 750-244-2

MISCELLANEOUS

Interactive Electronics Technical Manual (IETM) for Calibration and Repair Requirements for Maintenance of Army Materiel	TB 43-180
Consolidated Index of Army Publications and Blank Forms	DA PAM 25-30
First Aid	FM 4-25.11
Safety Requirements for Maintenance of Electrical and Electronic Equipment	TB 385-4
The Army Maintenance Management System (TAMMS) Users Manual	DA PAM 750-8
Functional Users Manual for the Army Maintenance Management System-Aviation (TAMMS-A)	DA PAM 738-751
Army Medical Department Expendable/Durable Items	CTA 8-100
Common Table of Allowances, Expendable/Durable Items (Except Medical, Class V, Repair Parts and Heraldic Items)	CTA 50-970

END OF WORK PACKAGE

INTRODUCTION

The Army Maintenance System MAC

This introduction provides a general explanation of all maintenance and repair function authorized at the two maintenance levels under the Two-Level Maintenance System concept.

This MAC (immediately following the introduction) designates overall authority and responsibility for the performance of maintenance functions on the identified end item or component. The application of the maintenance functions to the end item or component levels, which are shown on the MAC in column (4) as:

Field – includes two columns, Unit maintenance and Direct Support maintenance. The Unit maintenance column is divided again into two more subcolumns, C for Operator or Crew and O for Unit maintenance.
Sustainment – includes two subcolumns, general support (H) and depot (D).

The tools and test equipment requirements (immediately following the MAC) list the tools and test equipment (both special tools and common tool sets) required for each maintenance function as referenced from the MAC.

The remarks (immediately following the tools and test equipment requirements) contain supplemental instructions and explanatory notes for a particular maintenance function.

Maintenance Functions

Maintenance functions are limited to and defined as follows:

1. Inspect. To determine the serviceability of an item by comparing its physical, mechanical, and/or electrical characteristics with established standards through examination (e.g. by sight, sound, or feel). This includes scheduled inspection and gagings and evaluation of cannon tubes.
2. Test. To verify serviceability by measuring the mechanical, pneumatic, hydraulic, or electrical characteristics of an item and comparing those characteristics with prescribed standards on a scheduled basis, i.e., load testing of lift devices and hydrostatic testing of pressure hoses.
3. Service. Operations required periodically to keep an item in proper operating condition; e.g., to clean (includes decontaminate, when required), to preserve, to drain, to paint, or to replenish fuel, lubricants, chemical fluids, or gases. This includes scheduled exercising and purging of recoil mechanisms. The following are examples of service functions:
 - a. Unpack. To remove from packing box for service or when required for the performance of maintenance operations.
 - b. Repack. To return item to packing box after service and other maintenance operations.
 - c. Clean. To rid the item of contamination.
 - d. Touch up. To spot paint scratched or blistered surfaces.
 - e. Mark. To restore obliterated identification.
4. Adjust. To maintain or regulate, within prescribed limits, by bringing into proper position, or by setting the operating characteristics to specified parameters.
5. Align. To adjust specified variable elements of an item to bring about optimum or desired performance.

6. Calibrate. To determine and cause corrections to be made or to be adjusted on instruments of test, measuring, and diagnostic equipment used in precision measurement. Consists of comparisons of two instruments, one of which is a certified standard of known accuracy, to detect and adjust any discrepancy in the accuracy of the instrument being compared.
7. Remove/install. To remove and install the same item when required to perform service or other maintenance functions. Install may be the act of emplacing, seating, or fixing into position a spare, repair part, or module (component or assembly) in a manner to allow the proper functioning of an equipment or system.
8. Paint. To prepare and spray color coats of paint so that the ammunition can be identified and protected. The color indicating primary use is applied, preferably, to the entire exterior surface as the background color of the item. Other markings are to be repainted as original so as to retain proper ammunition identification.
9. Replace. To remove an unserviceable item and install a serviceable counterpart in its place "Repair" is authorized by the MAC and assigned maintenance level is shown as the third position code of the Source, Maintenance and Recoverability (SMR) code.
10. Repair. The application of maintenance services, including fault location/troubleshooting, removal/installation, disassembly/assembly procedures and maintenance actions to identify troubles and restore serviceability to an item by correcting specific damage, fault, malfunction, or failure in a part, subassembly, module (component or assembly), end item or system.

NOTE

The following definitions are applicable to the "repair" maintenance function:

Services. Inspect, test, service, adjust, align, calibrate, and/or replace.

Fault location/troubleshooting. The process of investigating and detecting the cause of equipment malfunctioning; the act of isolating a fault within a system or Unit Under Test (UUT).

Disassembly/assembly. The step-by-step breakdown (taking apart) of a spare/functional group coded item to the level of its least component, that is assigned an SMR code for the level of maintenance under consideration (i.e., identified as maintenance significant).

Actions. Welding, grinding, riveting, straightening, facing, machining, and/or resurfacing.

11. Overhaul. That maintenance effort (service/action) prescribed to restore an item to a completely serviceable/operational condition as required by maintenance standards in appropriate technical publications. Overhaul is normally the highest degree of maintenance performed by the Army. Overhaul does not normally return an item to like new condition.
12. Rebuild. Consists of those services/actions necessary for the restoration of unserviceable equipment to a like new condition in accordance with original manufacturing standards. Rebuild is the highest degree of material maintenance applied to Army equipment. The rebuild operation includes the act of returning to zero those age measurements (e.g., hours/miles) considered in classifying Army equipment/components.

Explanation of Columns in the MAC

Column (1) Group Number. Column (1) lists FGC numbers, the purpose of which is to identify maintenance significant components, assemblies, subassemblies, and modules with the Next Higher Assembly (NHA).

Column (2) Component/Assembly. Column (2) contains the item names of components, assemblies, subassemblies, and modules for which maintenance is authorized.

Column (3) Maintenance Function. Column (3) lists the functions to be performed on the item listed in column (2). (For a detailed explanation of these functions, refer to "Maintenance Functions" outlined above).

Column (4) Maintenance Level. Column (4) specifies each level of maintenance authorized to perform each function listed in column (3), by indicating work time required (expressed as manhours in whole hours or decimals) in the appropriate subcolumn. The work time figure represents the active time required to perform that maintenance function at the indicated level of maintenance. If the number or complexity of the tasks within the listed maintenance function varies at different maintenance levels, appropriate work time figures are to be shown for each level. The work time figure represents the average time required to restore an item (assembly, subassembly, component, module, end item or system) to a serviceable condition under typical field operating conditions. This time includes preparation time (including any necessary disassembly/assembly time), troubleshooting/fault location time, and quality assurance time in addition to the time required to perform the specific tasks identified for the maintenance functions authorized in the MAC. The symbol designations for the various maintenance levels are as follows:

Field:

- C Operator or Crew maintenance
- O Unit maintenance
- F Direct Support maintenance

Sustainment:

- L Specialized Repair Activity
- H General Support maintenance
- D Depot maintenance

NOTE

The "L" maintenance level is not included in column (4) of the MAC. Functions to this level of maintenance are identified by work time figure in the "H" column of column (4), and an associated reference code is used in the REMARKS column (6). This code is keyed to the remarks and the SRA complete repair application is explained there.

Column (5) Tools and Equipment Reference Code. Column (5) specifies, by code, those common tool sets (not individual tools), common Test, Measurement and Diagnostic Equipment (TMDE), and special tools, special TMDE and special support equipment required to perform the designated function. Codes are keyed to the entries in the tools and test equipment table.

Column (6) Remarks Code. When applicable, this column contains a letter code, in alphabetical order, which is keyed to the remarks table entries.

**TEST SET, RADAR, TS-4530/UPM
MAINTENANCE ALLOCATION CHART (MAC)**

Table 1. MAC for Test Set, Radar, TS-4530/UPM

(1) GROUP NUMBER	(2) COMPONENT/ASSEMBLY	(3) MAINTENANCE FUNCTION	(4) MAINTENANCE LEVEL						(5) TOOLS AND EQUIPMENT REFERENCE CODE	(6) REMARKS
			FIELD			SUSTAINMENT				
			UNIT		DS	GS		DEPOT		
			C	O	F	H	D			
00	IFF RADAR TEST SET TS-4530/UPM	INSPECT	C	0.1						A
		INSPECT		0.1	0.5			1		B
		TEST			1.0			1-12		C
		SERVICE		0.3						D
01	UPPER HOUSING ASSY (Not a procurable item)	REPAIR		0.5						E
		REPAIR		0.5						G
		REPAIR		8				1-12		F,I
		REPAIR/CALIBRATE						1-12		H
0101	RF BOARD A2	INSPECT			0.3			1		B
		TEST			0.5			1-12		D
		REPLACE			0.5			1		F,I
		REPAIR					1.0			L
0102	DSP BOARD A1	INSPECT			0.3			1		B
		TEST			0.5			1-12		D
		REPLACE			0.5			1		F,I
		REPAIR					1.0			L
0103	DISPLAY BOARD A3	INSPECT			0.3			1		B
		TEST			0.5			1-12		D
		REPLACE			0.5			1		F,I
		REPAIR					1.0			L
02	LOWER HOUSING ASSY (Not a procurable item)	INSPECT			0.3			1		B
		TEST			0.5			1-12		D
		REPAIR			0.5			1		F,I,M
0201	POWER SUPPLY BOARD A4	INSPECT			0.3			1		B
		TEST			0.5			1-12		D
		REPLACE			0.5			1		F,I
		REPAIR					1.0			L
0202	ATTENUATOR ASSEMBLY	INSPECT			0.3			1		B
		TEST			0.5			1-12		D
		REPLACE			0.5			1		F,I
		REPAIR								N
03	CABLE ASSEMBLY KIT/KIR INTERFACE	INSPECT			0.3			1		B
		TEST			1.0			1-12		D
		REPLACE			1.0			1		F,I
		REPAIR					1.0			L

Table 2. Tools and Test Equipment for TEST SET, RADAR, TS-4530/UPM

(1) TOOLS OR TEST EQUIPMENT REF CODE	(2) MAINTENANCE LEVEL	(3) NOMENCLATURE	(4) NATIONAL STOCK NUMBER	(5) TOOL NUMBER
1	H	Tool Kit, Calibration Tech	5180-01-308-3380	JTK-17 (52346)
2	H	Power Supply, 28 VDC	6695-01-142-4682	7916707 (66015)
3	H	Measuring Receiver	6625-01-169-7744	8902A (1LQK8)
4	H	Signal Generator	6625-01-395-9570	68347M (0T1F7)
5	H	Global Positioning System (Frequency Standard)	7110-01-481-8370	13589305
6	H	Directional Coupler	5985-01-048-7881	778D
7	H	Cable, Type-N, 152-cm (60-in.) (2 required)	5995-01-333-8957	11500D (1LQK8)
8	H	Adapter, N(f) to SMA(f)	5935-01-119-7450	4299
9	H	Sensor Module	6625-01-169-7669	11722A (1LQK8)
10	H	Amplifier, Radio Frequency	TBD	TBD
11	H	Multimeter	6625-01-221-9367	AN/GSM-64D (89536)
12	H	PC Computer (See Note)		

Note: Computer requirements are for a computer with a minimum operating system of Windows 95 or later, 1 RS 232 port and 1 CD ROM Drive (for bench utility installation)

Table 3. Remarks for Test Set, Radar, TS-4530/UPM

REMARKS CODE	REMARKS
A	Perform thorough external visual inspection.
B	External/internal vision inspections of all assemblies, boards, and electrical connections.
C	Performance Tests.
D	Performance and troubleshooting tests.
E	IAW Preventive Maintenance, Checks and Services (PMCS).
F	IAW the maintenance procedure contained within the IETM.
G	Limited to the replacement of accessories (external components of end item (COEI), basic issue items (BII) including power cables, battery stick, battery contact assembly, battery tube assembly, serial data cable, RF direct connect cable assembly, DC cable, and external power supply.
H	IAW procedures indicated by TB 43-180.
I	Repair by replacement of defective assembly.
J	Performance of applicable maintenance adjustments.
K	Repair by replacement of Antenna Assembly, W3 or W4 cable.
L	Repair defective assemblies by replacing defective piece parts.
M	Repair by replacement of A7, Main Connector Assembly.
N	Repair be replacement of AT1P2, Conn Housing DBL Row CNT POL 10 POS.

INTRODUCTION

Scope

This work package lists COEI and BII for the Radar Test Set, TS-4530/UPM to help you inventory items for safe and efficient operation of the equipment.

General

The COEI and BII information is divided into the following lists:

Components of End Item (COEI). This listing is for information purposes only, and is not authority to requisition replacements. These items are part of the Radar Test Set, TS-4530/UPM. As part of the end item, these items must be with the end item whenever it is issued or transferred between property accounts. Items of COEI are removed and separately packaged for transportation or shipment only when necessary. Illustrations are furnished to help you find and identify the items.

Basic Issue Items (BII). These essential items are required to place the Radar Test Set, TS-4530/UPM in operation, operate it, and do emergency repairs. Although shipped separately packaged, BII must be with the Radar Test Set, TS-4530/UPM during operation and when it is transferred between property accounts. Listing these items is your authority to request/requisition them for replacement based on authorization of the end item by the TOE/MOE. Illustrations are furnished to help you find and identify the items.

Explanation of Columns in the COEI List and BII List

The following is an explanation of columns found in the tabular listings.

Column (1) - Illus Number, gives you the number of the item illustrated.

Column (2) - National Stock Number (NSN), identifies the stock number of the item to be used for requisitioning purposes.

Column (3) - Description, CAGEC, and Part Number, identifies the Federal item name (in all capital letters) followed by a minimum description when needed. The stowage location of COEI and BII is also included in this column. The last line below the description is the CAGEC (commerical and Government entity code) (in parenthesis) and the part number.

Column (4), Usable on Code, gives you a code if the item you need is not the same for different models of equipment. These codes are identified below:

<u>Code</u>	<u>Used On</u>
-------------	----------------

Column (5), U/M (unit of measure), indicates how the item is issued for the National Stock Number shown in column (2).

Column (6), Qty Rqr, indicates the quantity required.

COMPONENTS OF END ITEM (COEI) LIST

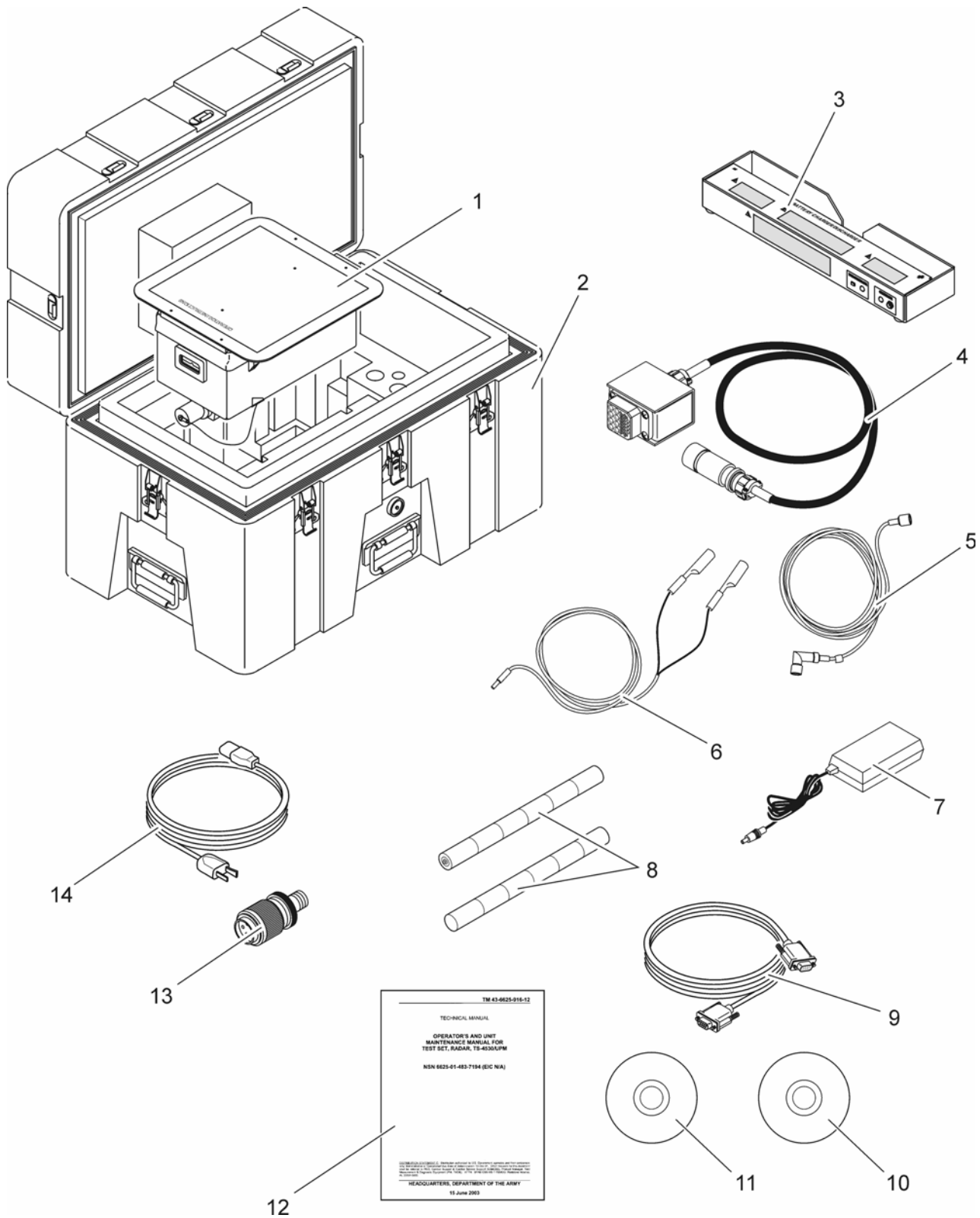

(1) ILLUS NUMBER	(2) NATIONAL STOCK NUMBER	(3) DESCRIPTION CAGEC AND PART NUMBER	(4) USABLE ON CODE	(5) U/M	(6) QTY RQR
1		TEST SET, RADAR, TS-4530/UPM (41364) 01-1045-70		EA	1
2		TRANSIT CASE AND LID (41364) 15-5299-01		EA	1
3		BATTERY CHARGER/DISCHARGER (41364) 01-1045-10		EA	1
4		CABLE, KIT/KIR-1C INTERFACE (115 VAC) (41364) 55-1045-10		EA	1
5		CABLE ASSEMBLY, RF DIRECT CONNECT (41364) 55-1045-11 (with Cable Cal Factor Tag)		EA	1
6		DC POWER CABLE (41364) 55-1045-14		EA	1
7		AC ADAPTER (41364) 15-0360-M0		EA	1
8		BATTERY, SEALED, NI-CAD RECHARGEABLE (BATTERY STICK) (41364) 43-0012-00		EA	2
9		RS-232 CABLE, 9-PIN (41364) 55-1045-15		EA	1
10		CD-ROM, OPERATOR TRAINING SOFTWARE (41364) 60-0694-B3		EA	1
11		CD-ROM, BENCH UTILITY SOFTWARE (41364) 60-0694-B5		EA	1
12		MANUAL, OPERATION AND MAINTENANCE (41364) 06-1045-72		EA	1
13		RF ADAPTER (41364) 30-0225-01		EA	1
14		POWER CORD (41364) 24-7060-10		EA	1

END OF WORK PACKAGE

INTRODUCTION

Scope

This work package lists expendable and durable items that you will need to operate and maintain the Radar Test Set, TS-4530/UPM. This list is for information only and is not authority to requisition the listed items. These items are authorized to you by CTA 50-970, Common Table of Allowances, Expendable/Durable Items (Except Medical, Class V, Repair Parts and Heraldic items), or CTA 8-100, Army Medical Department Expendable/Durable Items.

Explanation of Columns in the Expendable/Durable Items list

Column (1) - Item Number. This number is assigned to the entry in the list and is referenced in the narrative instructions to identify the item (e.g., "Use brake fluid (item 5, WP 0098 00).

Column (2) - Level. This column identifies the lowest level of maintenance that requires the item (C = Operator/ Crew).

Column (3) - National Stock Number. This is the NSN assigned to the item which you can use to requisition it.

Column (4) - Item Name, Description, Commercial and Government entity Code (CAGEC), and Part Number. This column provides the other information you need to identify the item.

Column (5) - Unit of Measure (U/M). This code shows the physical measurement or count of an item such as gallon, dozen, gross, etc.

Table 1. Expendable and Durable Items List.

(1) ITEM NUMBER	(2) LEVEL	(3) NATIONAL STOCK NUMBER	(4) ITEM NAME, DESCRIPTION, CAGEC, PART NUMBER	(5) U/M
1	C	8305-00-267-3015	Cloth, Cheesecloth, Cotton, Lintless, CCC-C-440, Type II, Class 2 (81349)	YD
2	C	6810-00-753-4993	Alcohol, Isopropyl, 8 oz. Can, TT-I-735, Grade A (81348)	OZ
3	C	7930-00-068-1669	Detergent, Mild, Liquid	OZ
4	C, O		Brush, MIL-G-724	EA

END OF WORK PACKAGE

By Order of the Secretary of the Army:

Official:

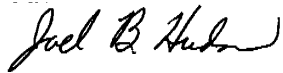

JOEL B. HUDSON
Administrative Assistant to the
Secretary of the Army
0334404

PETER J. SCHOOMAKER
General, United States Army
Chief of Staff

These are the instructions for sending an electronic 2028

The following format must be used if submitting an electronic 2028. The subject line must be exactly the same and all fields must be included; however only the following fields are mandatory: 1, 3, 4, 5, 6, 7, 8, 9, 10, 13, 15, 16, 17, and 27.

From: "Whomever" <whomever@wherever.army.mil>

To: 2028@redstone.army.mil

Subject: DA Form 2028

1. **From:** Joe Smith
2. **Unit:** home
3. **Address:** 4300 Park
4. **City:** Hometown
5. **St:** MO
6. **Zip:** 77777
7. **Date Sent:** 19-OCT-93
8. **Pub no:** 55-2840-229-23
9. **Pub Title:** TM
10. **Publication Date:** 04-JUL-85
11. **Change Number:** 7
12. **Submitter Rank:** MSG
13. **Submitter FName:** Joe
14. **Submitter MName:** T
15. **Submitter LName:** Smith
16. **Submitter Phone:** 123-123-1234
17. **Problem:** 1
18. **Page:** 2
19. **Paragraph:** 3
20. **Line:** 4
21. **NSN:** 5
22. **Reference:** 6
23. **Figure:** 7
24. **Table:** 8
25. **Item:** 9
26. **Total:** 123
27. **Text:**

This is the text for the problem below line 27.

RECOMMENDED CHANGES TO PUBLICATIONS AND BLANK FORMS For use of this form, see AR 25-30; the proponent agency is ODISC4.						Use Part II (reverse) for Repair Parts and Special Tool Lists (RPSTL) and Supply Catalogs/Supply Manuals (SC/SM)	DATE 8/30/02
TO: (Forward to proponent of publication or form)(Include ZIP Code) Commander, U.S. Army Aviation and Missile Command ATTN: AMSAM-MMC-MA-NP Redstone Arsenal, AL 35898						FROM: (Activity and location)(Include ZIP Code) MSG, Jane Q. Doe 1234 Any Street Nowhere Town, AL 34565	
PART 1 - ALL PUBLICATIONS (EXCEPT RPSTL AND SC/SM) AND BLANK FORMS							
PUBLICATION/FORM NUMBER TM 43-6625-916-12						DATE 16 Sep 2002	TITLE Organizational, Direct Support, And General Support Maintenance Manual for Machine Gun, .50 Caliber M3P and M3P Machine Gun Electrical Test Set Used On Avenger Air Defense Weapon System
ITEM NO.	PAGE NO.	PARA-GRAPH	LINE NO. *	FIGURE NO.	TABLE NO.	RECOMMENDED CHANGES AND REASON	
1	WP0005 PG 3		2			Test or Corrective Action column should identify a different WP number.	
EXAMPLE							
<i>* Reference to line numbers within the paragraph or subparagraph.</i>							
TYPED NAME, GRADE OR TITLE MSG, Jane Q. Doe, SFC						TELEPHONE EXCHANGE/AUTOVON, PLUS EXTENSION 788-1234	SIGNATURE

TO: (Forward direct to addressee listed in publication) Commander, U.S. Army Aviation and Missile Command ATTN: AMSAM-MMC-MA-NP Redstone Arsenal, AL 35898	FROM: (Activity and location) (Include ZIP Code) MSG, Jane Q. Doe 1234 Any Street Nowhere Town, AL 34565	DATE 8/30/02
--	--	------------------------

PART II - REPAIR PARTS AND SPECIAL TOOL LISTS AND SUPPLY CATALOGS/SUPPLY MANUALS

PUBLICATION NUMBER			DATE	TITLE				
PAGE NO.	COLM NO.	LINE NO.	NATIONAL STOCK NUMBER	REFERENCE NO.	FIGURE NO.	ITEM NO.	TOTAL NO. OF MAJOR ITEMS SUPPORTED	RECOMMENDED ACTION

PART III - REMARKS (Any general remarks, corrections, or suggestions for improvement of publications and blank forms. Additional blank sheets may be used if more space is needed.)

EXAMPLE

TYPED NAME, GRADE OR TITLE MSG, Jane Q. Doe, SFC	TELEPHONE EXCHANGE/AUTOVON, PLUS EXTENSION 788-1234	SIGNATURE
---	---	-----------

RECOMMENDED CHANGES TO PUBLICATIONS AND BLANK FORMS For use of this form, see AR 25-30; the proponent agency is ODISC4.	Use Part II (reverse) for Repair Parts and Special Tool Lists (RPSTL) and Supply Catalogs/Supply Manuals (SC/SM)	DATE
---	--	------

TO: (Forward to proponent of publication or form)(Include ZIP Code) Commander, U.S. Army Aviation and Missile Command ATTN: AMSAM-MMC-MA-NP Redstone Arsenal, AL 35898	FROM: (Activity and location)(Include ZIP Code)
---	---

PART 1 - ALL PUBLICATIONS (EXCEPT RPSTL AND SC/SM) AND BLANK FORMS

PUBLICATION/FORM NUMBER	DATE	TITLE
-------------------------	------	-------

ITEM NO.	PAGE NO.	PARA-GRAPH	LINE NO. *	FIGURE NO.	TABLE NO.	RECOMMENDED CHANGES AND REASON

* Reference to line numbers within the paragraph or subparagraph.

TYPED NAME, GRADE OR TITLE	TELEPHONE EXCHANGE/ AUTOVON, PLUS EXTENSION	SIGNATURE
----------------------------	--	-----------

TO: (Forward direct to addressee listed in publication) Commander, U.S. Army Aviation and Missile Command ATTN: AMSAM-MMC-MA-NP Redstone Arsenal, AL 35898	FROM: (Activity and location) (Include ZIP Code)	DATE
--	---	-------------

PART II - REPAIR PARTS AND SPECIAL TOOL LISTS AND SUPPLY CATALOGS/SUPPLY MANUALS

PUBLICATION NUMBER			DATE	TITLE				
PAGE NO.	COLM NO.	LINE NO.	NATIONAL STOCK NUMBER	REFERENCE NO.	FIGURE NO.	ITEM NO.	TOTAL NO. OF MAJOR ITEMS SUPPORTED	RECOMMENDED ACTION

PART III - REMARKS (Any general remarks or recommendations, or suggestions for improvement of publications and blank forms. Additional blank sheets may be used if more space is needed.)

TYPED NAME, GRADE OR TITLE	TELEPHONE EXCHANGE/AUTOVON, PLUS EXTENSION	SIGNATURE
----------------------------	--	-----------

